

MİMARİ KATALOG

ARCHITECTURAL CATALOGUE

Alüminyum Kapı Pencere ve Giydirme Cephe Sistemleri
Aluminium Door Window and Facade Systems



RST58

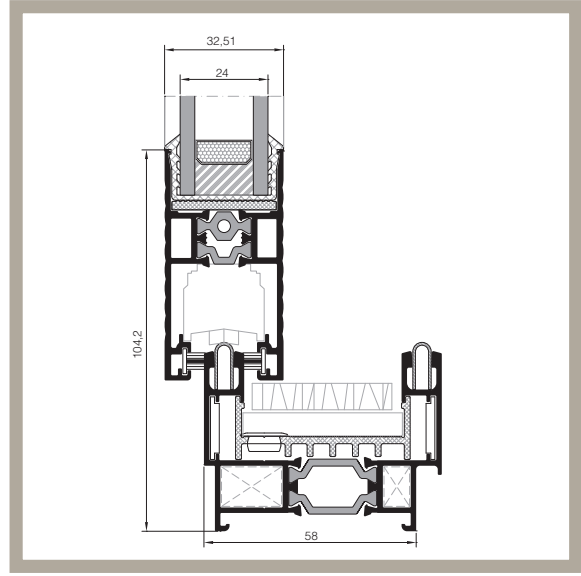

TEKNİK ÖZELLİKLER / TECHNICAL PROPERTIES

KASA DERİNLİĞİ / FRAME DEPTH	min. 65 mm - max. 139,5 mm
KANAT DERİNLİĞİ / VENT DEPTH	min. 39,6 mm - max. 84,72 mm
PROFİL ET KALINLIĞI / PROFILE WALL THICKNESS	1,4 / 1,5 / 1,6 mm
CAM KALINLIĞI / GLASS THICKNESS	20 / 22/ 24 mm
ISI BARIYERLERİ / THERMAL INSULATION BARS	14,8 / 20 / 24 mm

KULLANIM SEÇENEKLERİ / APPLICATION ALTERNATIVES

	KAPI DOOR	PENCERE WINDOW
BASİT SÜRME / SLIDING	•	•
90° KANAT BİRLEŞİMİ / 90° VENT COMBINATION	•	•
45° KANAT BİRLEŞİMİ / 45° VENT COMBINATION	•	•
CAM ÇİTALI KANAT / VENT WITH GLAZING BEAD	•	•
CAM ÇİTASIZ KANAT / VENT WITHOUT GLAZING BEAD	•	•
3 RAYLI KASA / 3 RAILED FRAME	•	•
SİNEKLİK / INSECT SCREEN	•	•
SABİTLE BİRLEŞİM / COMBINATION WITH FIXED PART	•	•

PERFORMANS DEĞERLERİ / PERFORMANCE VALUES

SİSTEM UF DEĞERİ - EN 10077-2
THERMAL INSULATION VALUE



4,20- 5,70W/M²K

ISI YALITIM DEĞERLERİ (UF) / Thermal Insulation Value (UF)

Cam Kalınlıkları: 20 / 22 / 24 mm
Glass Thickness

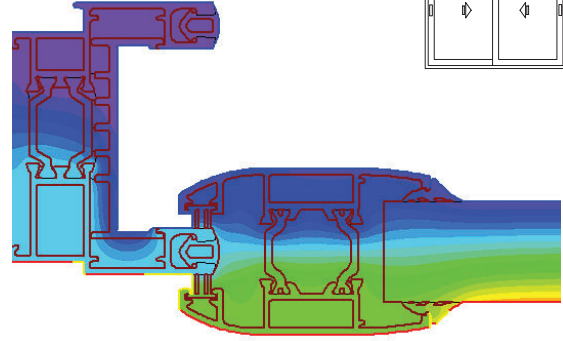
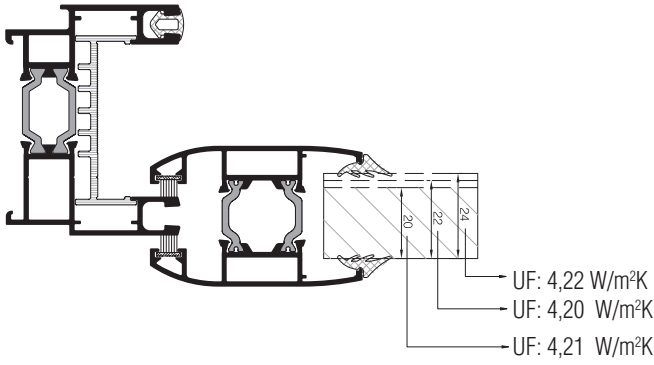

01

02

Cam Kalınlıkları: 20 / 22 / 24 mm
Glass Thickness

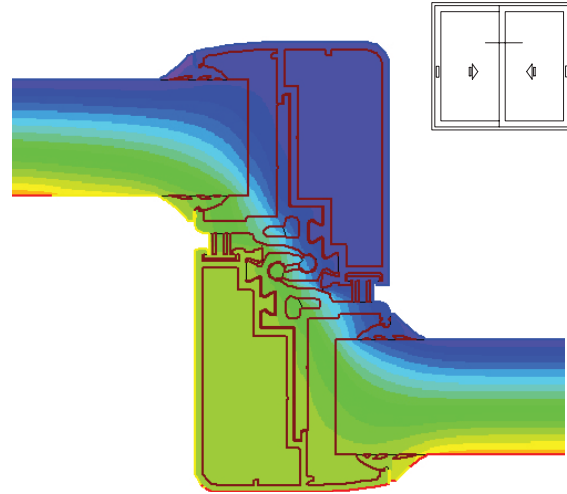
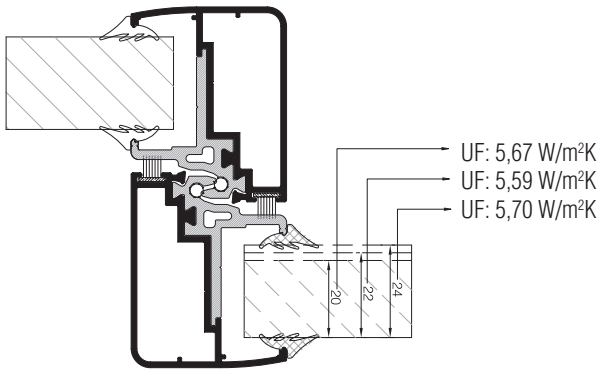

03

04

05

06

Cam Kalınlıkları: 20 / 22 / 24 mm
Glass Thickness

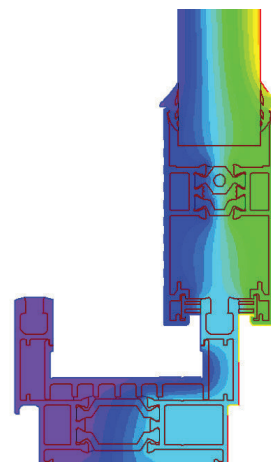
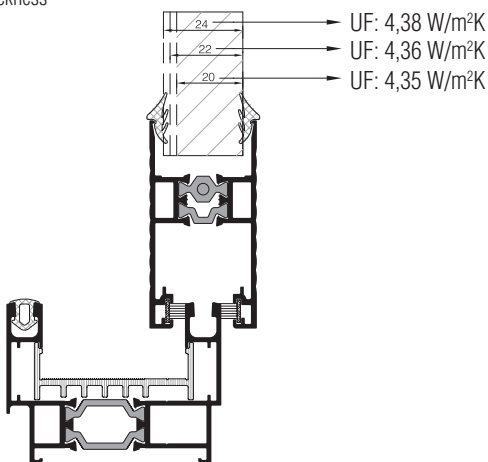

RÜZGAR YÜKÜNE GÖRE KULLANIM LİMİTLERİ GRAFIĞI
USAGE DIAGRAM FOR THE WIND LOAD

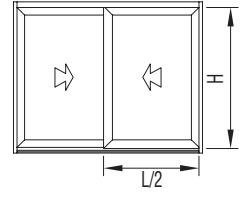
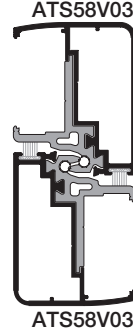
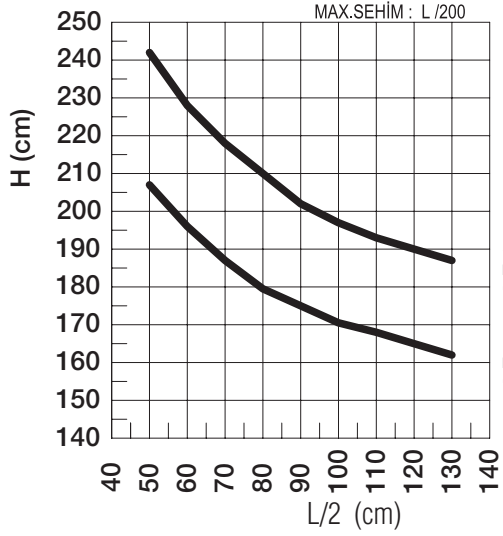

ATS58V03 Jx: 7,83 cm⁴
ATS58V03 Jx: 7,83 cm⁴
TOPLAM Jx: 15,66 cm⁴

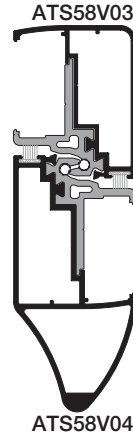
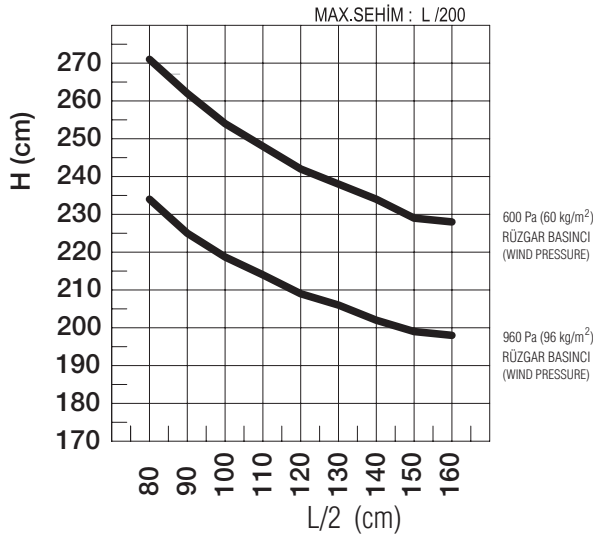

ATS58V03 Jx: 7,83 cm⁴
ATS58V04 Jx: 26,79 cm⁴
TOPLAM Jx: 34,62 cm⁴

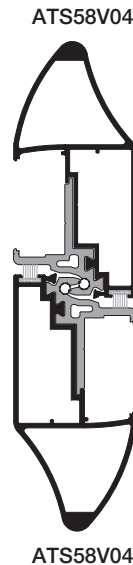
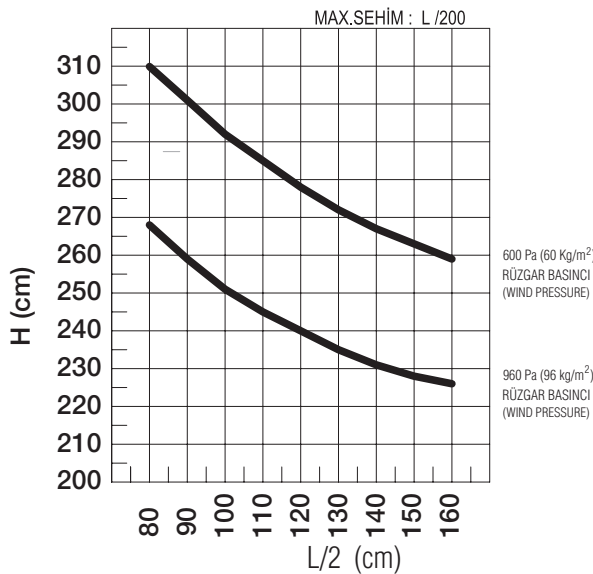

ATS58V04 Jx: 26,79 cm⁴
ATS58V04 Jx: 26,79 cm⁴
TOPLAM Jx: 53,58 cm⁴

01
02
03
04
05
06

SİSTEM TİPOLOJİSİ
SYSTEM TYPOLOGY

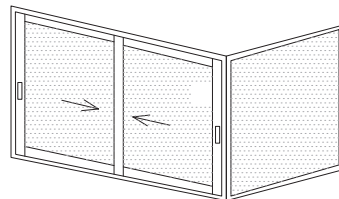
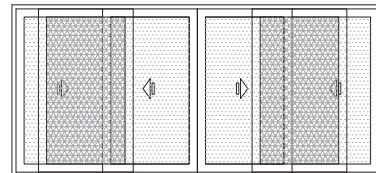
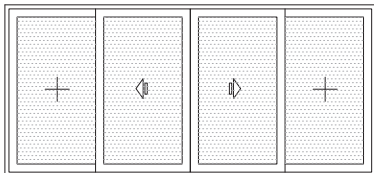
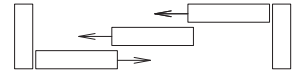
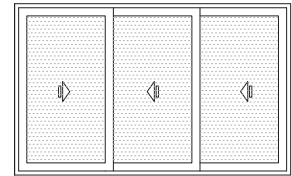
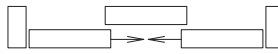
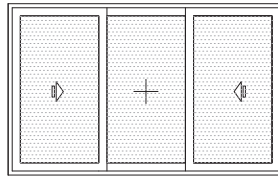
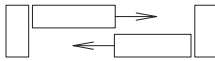
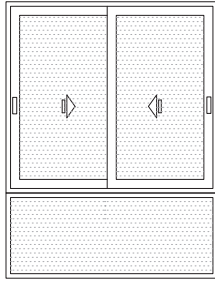
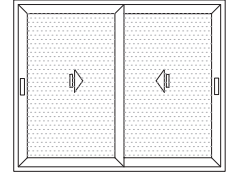
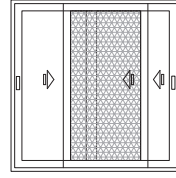
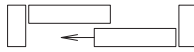
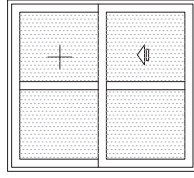
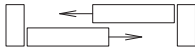
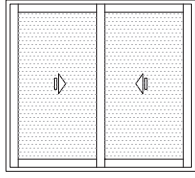

01

02

03

04

05

06

MİMARİ KATALOG

ARCHITECTURAL CATALOGUE

Alüminyum Kapı Pencere ve Giydirme Cephe Sistemleri
Aluminium Door Window and Facade Systems

RST58

PROFİLLER

PROFILES

01

02

03

04

05

06

KOD / CODE	AĞIRLIK (kg/m) / WEIGHT	Jxx cm ⁴	Jyy cm ⁴	L m	
ATS58F01	1,338	20,707	9,398	6	
ATS58F02	1,517	30,033	10,135	6	

ATS58F01

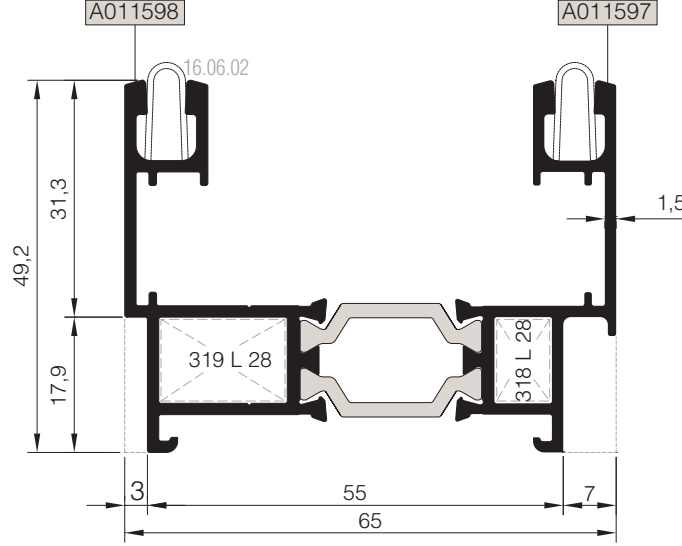

ATS58F02

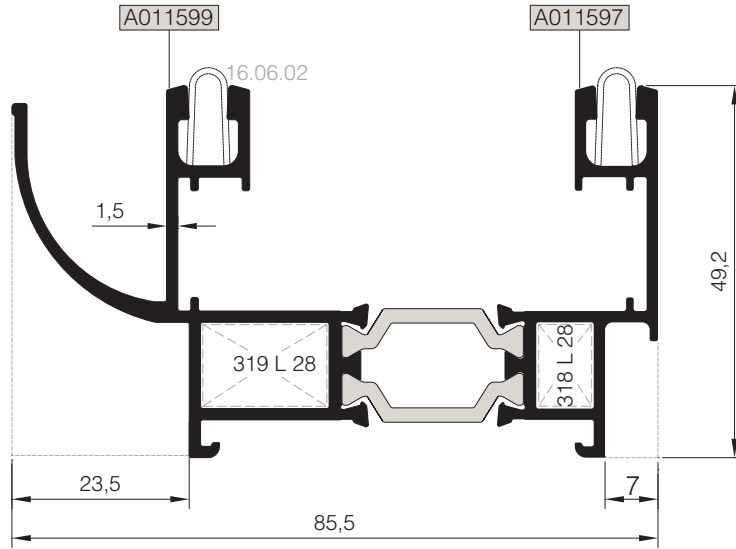

Nr		L m	KESİM ÖLÇÜSÜ CUTTING SIZE	AKS. KODU ACS. CODE
ATS58F01	A011597	25 L 28(A010542)	7,3 mm	318 L 28
	A011598	25 L 28(A010542)	16,7 mm	319 L 28
ATS58F02	A011597	25 L 28(A010542)	7,3 mm	318 L 28
	A011599	25 L 28(A010542)	16,7 mm	319 L 28

KOD / CODE	AĞIRLIK (kg/m) / WEIGHT	Jxx cm ⁴	Jyy cm ⁴	L m
ATS58F03	1,724	33,384	19,971	6
ATS58F08	1,471	23,794	13,848	6

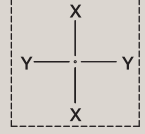

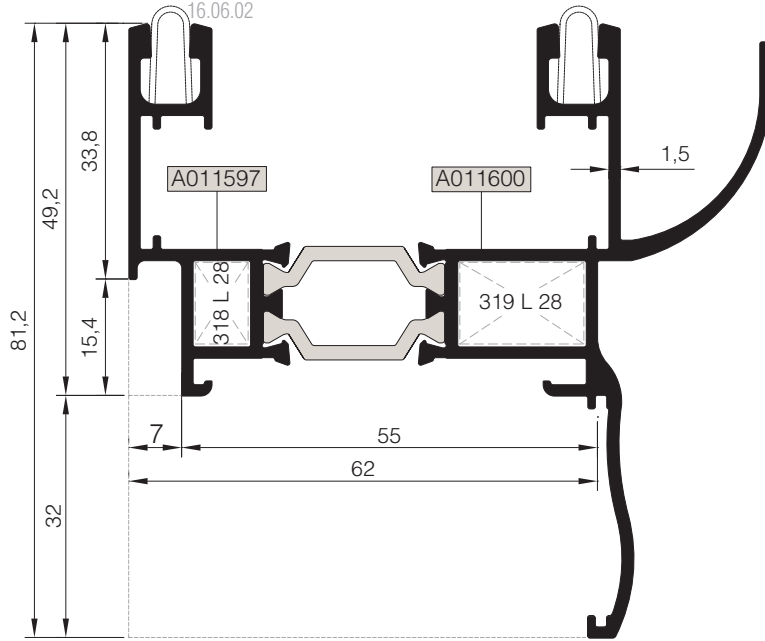

ATS58F03

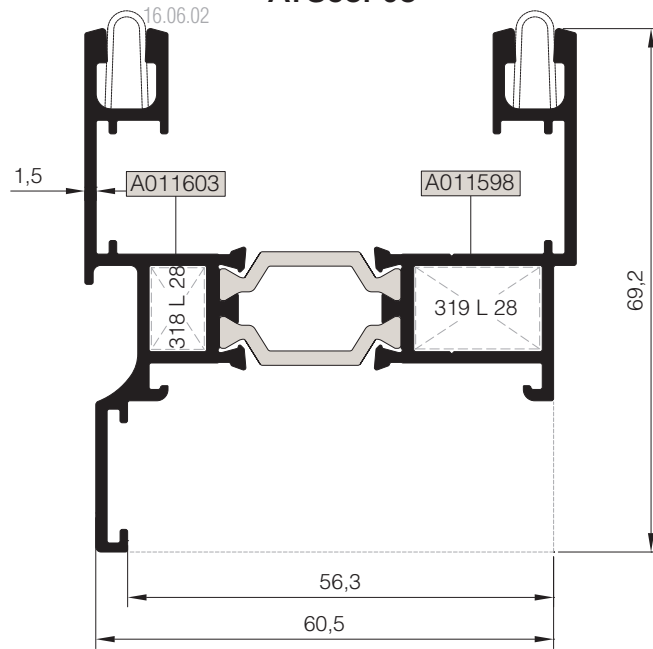

ATS58F08



Nr		 L m	KESİM ÖLÇÜSÜ CUTTING SIZE	 AKS. KODU ACS. CODE
ATS58F03	A011597	25 L 28 (A010542)	7,3 mm	318 L 28
	A011600	25 L 28 (A010542)	16,7 mm	319 L 28
ATS58F08	A011603	25 L 28 (A010542)	7,3 mm	318 L 28
	A011598	25 L 28 (A010542)	16,7 mm	319 L 28

KOD / CODE	AĞIRLIK (kg/m) / WEIGHT	Jxx cm ⁴	Jyy cm ⁴	L m	
ATS58F09	1,643	32,472	10,741	6	
ATS58F10	1,687	---	---	6	

ATS58F10

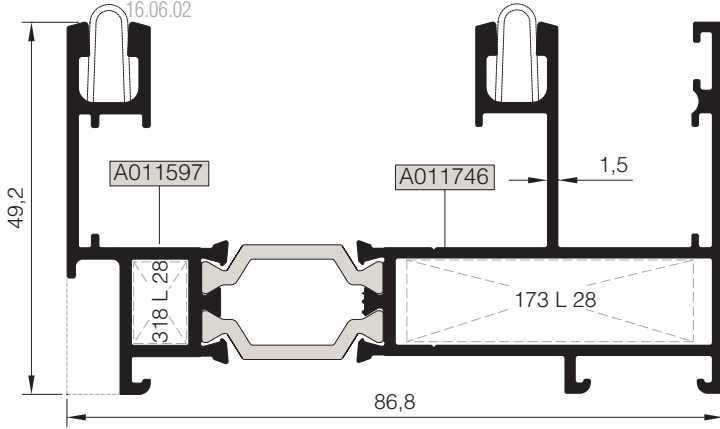

**ATS58F09

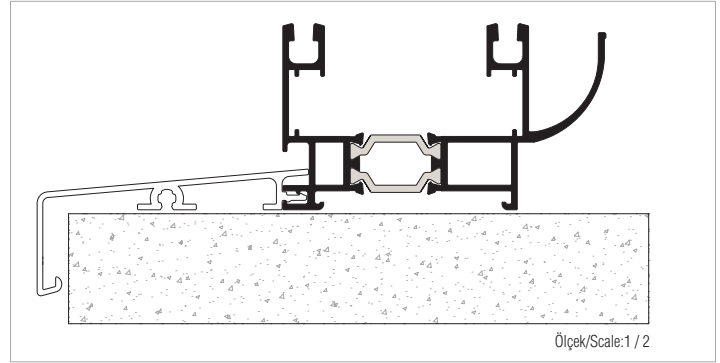
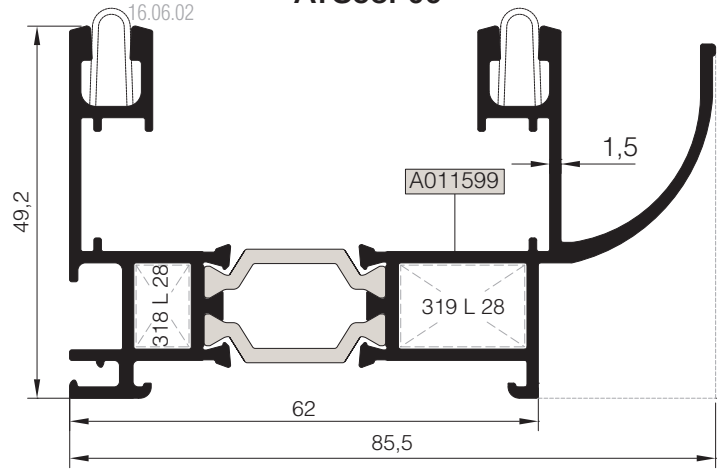

**Kalıp aktif değildir. Sipariş üzerine yapılacaktır.
The die is not active. It will be produced by order.

Nr		L m	KESİM ÖLÇÜSÜ CUTTING SIZE	AKS. KODU ACS. CODE
ATS58F09	---	25 L 28 (A010542)	7,3 mm	318 L 28
	A011599	25 L 28 (A010542)	16,7 mm	319 L 28
ATS58F10	A011597	25 L 28 (A010542)	7,3 mm	318 L 28
	A011746	25 L 28 (A010542)	37,9 mm	173 L 28

KOD / CODE	AĞIRLIK (kg/m) / WEIGHT	Jxx cm ⁴	Jyy cm ⁴	L m
ATS58F04	2,247	92,010	15,197	6
ATS58F05	2,426	117,022	16,029	6

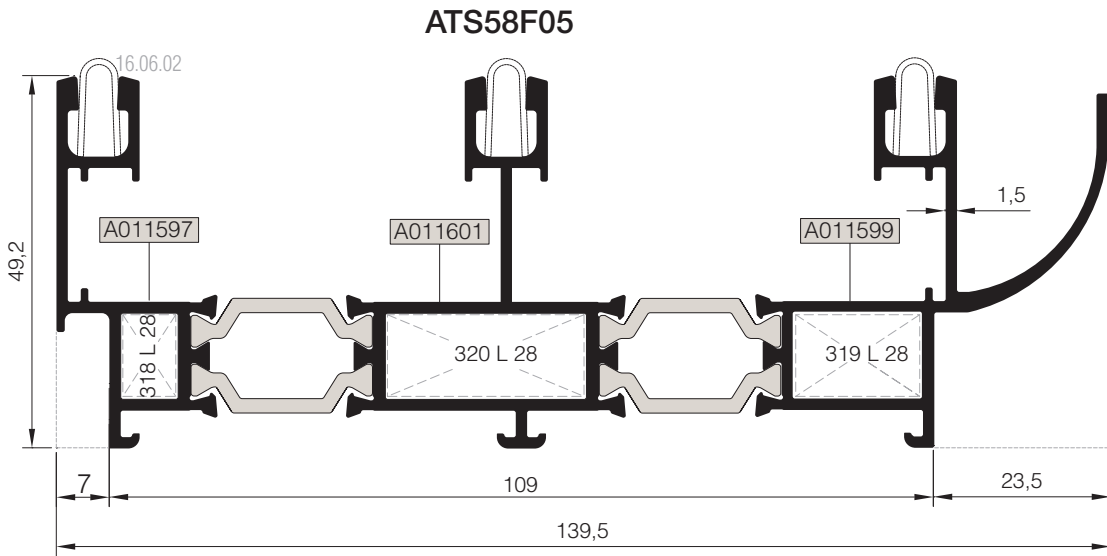
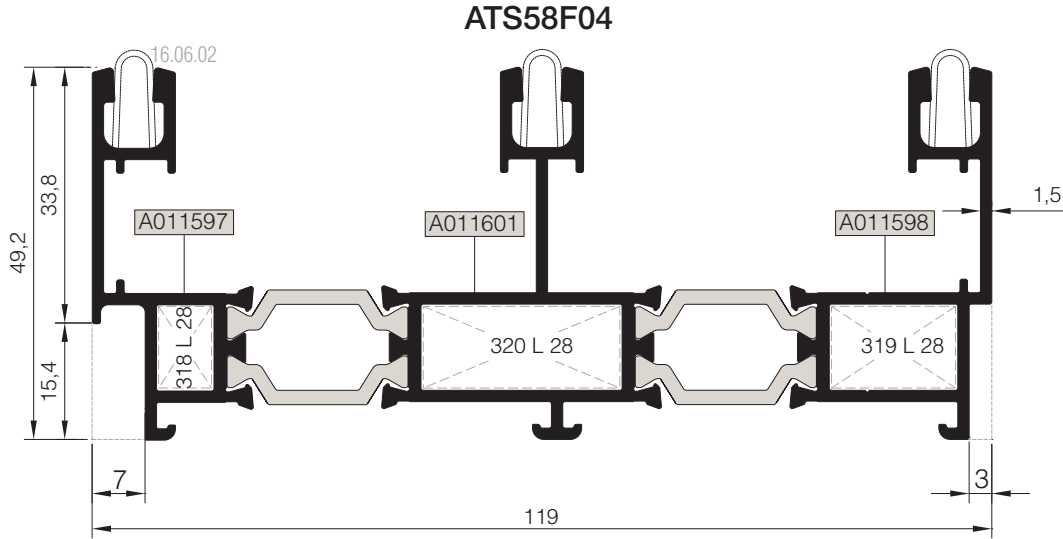
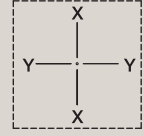

01



02

03

04

05

06

Nr	 L m	KESİM ÖLÇÜSÜ CUTTING SIZE	 AKS. KODU ACS. CODE	
ATS58F04	A011597	25 L 28 (A010542)	7,3 mm	318 L 28
	A011598	25 L 28 (A010542)	16,7 mm	319 L 28
	A011601	25 L 28 (A010542)	26,3 mm	320 L 28
ATS58F05	A011597	25 L 28 (A010542)	7,3 mm	318 L 28
	A011599	25 L 28 (A010542)	16,7 mm	319 L 28
	A011601	25 L 28 (A010542)	26,3 mm	320 L 28

KOD / CODE	AĞIRLIK (kg/m) / WEIGHT	Jxx cm ⁴	Jyy cm ⁴	L m	
ATS58F06	2,633	131,987	25,673	6	
ATS58F07	1,952	67,098	14,646	6	

ATS58F06

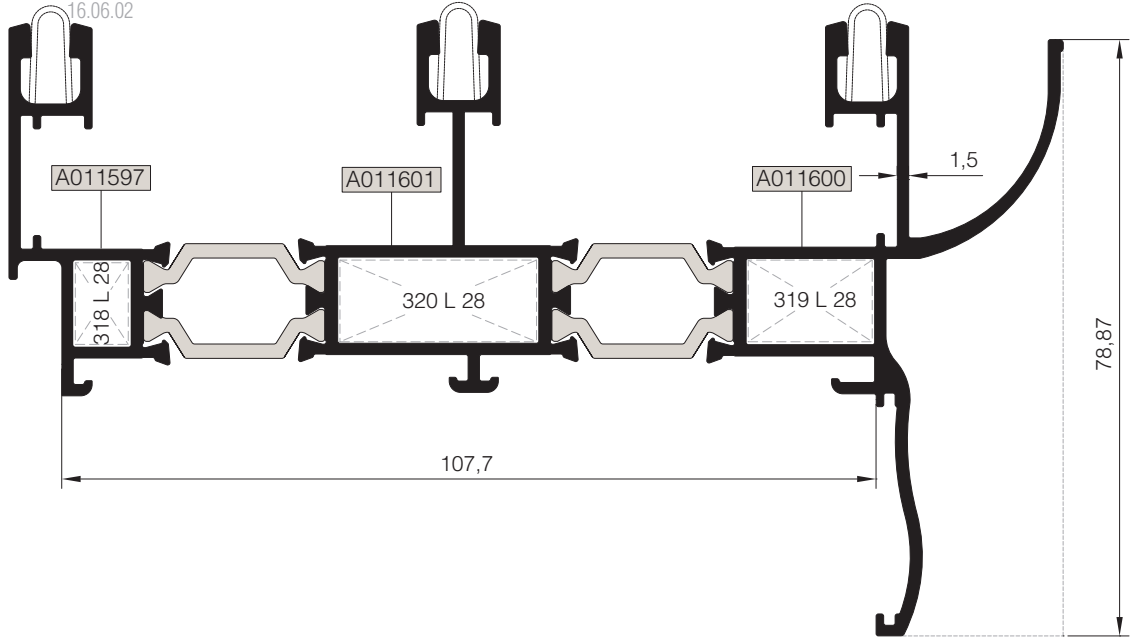

ATS58F07
Sineklik Kanadı İçin Kasa

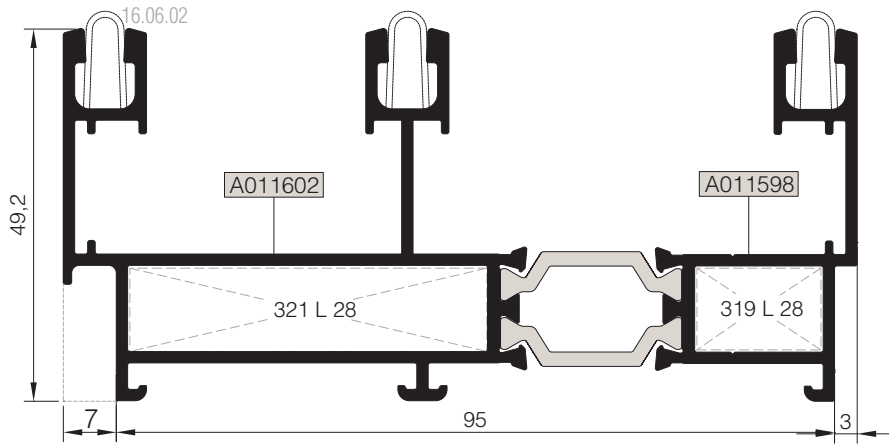

Nr		L m	KESİM ÖLÇÜSÜ CUTTING SIZE	AKS. KODU ACS. CODE
ATS58F06	A011597	25 L 28 (A010542)	7,3 mm	318 L 28
	A011600	25 L 28 (A010542)	16,7 mm	319 L 28
	A011601	25 L 28 (A010542)	26,3 mm	320 L 28
ATS58F07	A011598	25 L 28 (A010542)	16,7 mm	319 L 28
	A011602	25 L 28 (A010542)	47,3 mm	321 L 28

KOD / CODE	AĞIRLIK (kg/m) / WEIGHT	Jxx cm ⁴	Jyy cm ⁴	L m
ATS58F11	2,861	---	---	6
ATS58F12	2,323	---	---	6

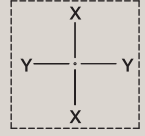

ATS58F11
Sineklik Kanadı İçin Kasa

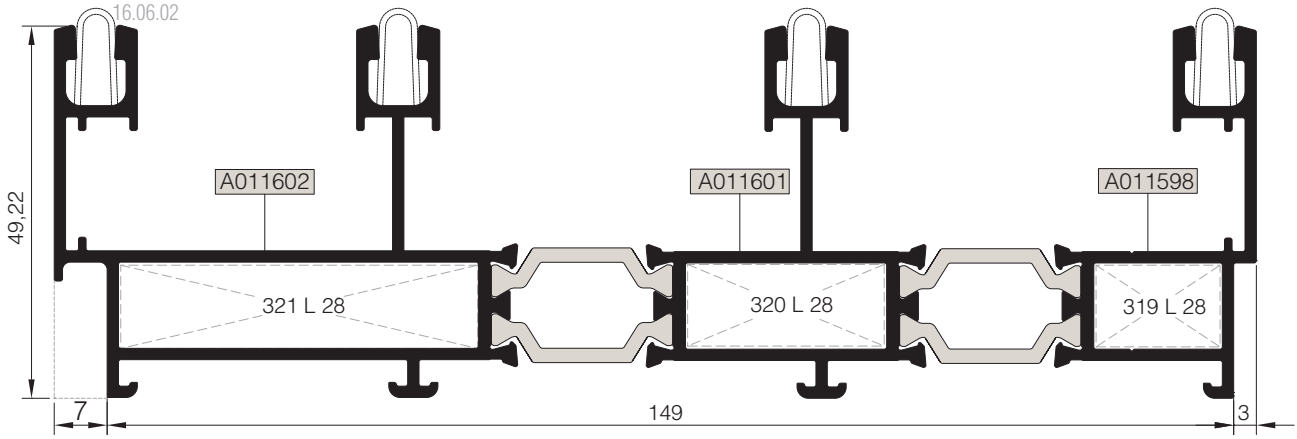

ATS58F12
Sineklik Kanadı İçin Kasa

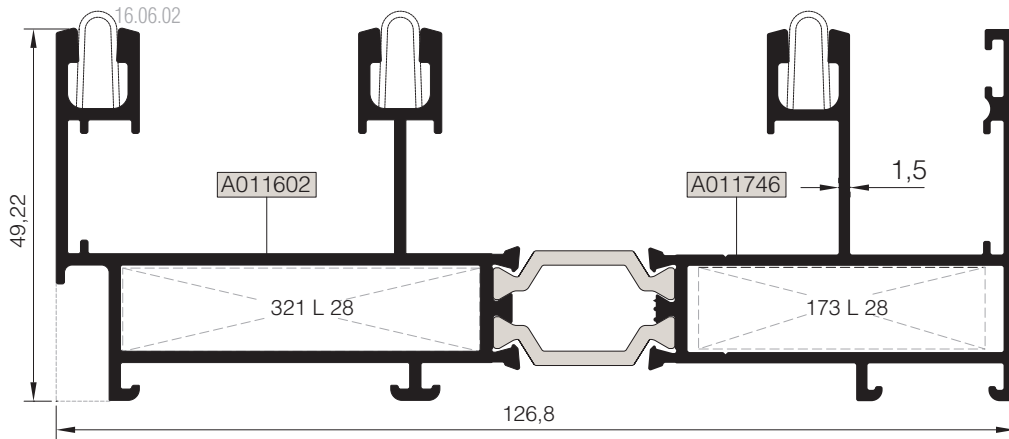

01

02

03

04

05

06

Nr		L m	KESİM ÖLÇÜSÜ CUTTING SIZE	AKS. KODU ACS. CODE
ATS58F11	A011602	25 L 28 (A010542)	47,3 mm	321 L 28
	A011601	25 L 28 (A010542)	26,3 mm	320 L 28
	A011598	25 L 28 (A010542)	16,7 mm	319 L 28
ATS58F12	A011602	25 L 28 (A010542)	47,3 mm	321 L 28
	A011746	25 L 28 (A010542)	37,9 mm	173 L 28

KOD / CODE	AĞIRLIK (kg/m) / WEIGHT	Jxx cm ⁴	Jyy cm ⁴	L m
ATS58V01	1,218	7,282	9,920	6
ATS58V02	1,290	8,112	15,440	6
ATS58V03	1,020	7,838	3,041	6
ATS58V04	1,444	26,799	5,616	6

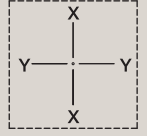

ATS58V01

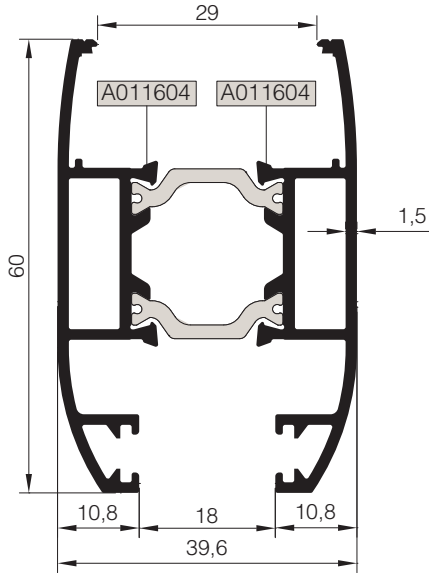

ATS58V02

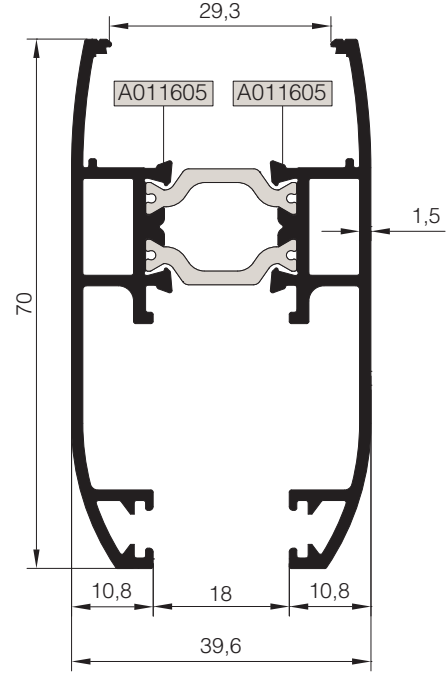

ATS58V04

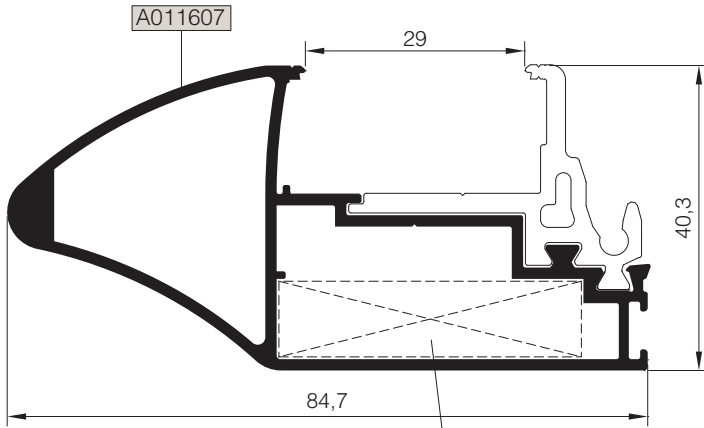

ATS58V03

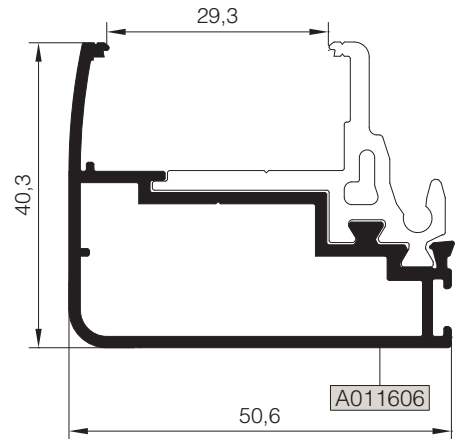

* Statiği arttırmak amacı ile profilin içerisine 10 mm. lik çelik lama konulabilir.
In order to increase the static, 10 mm flat steel can be inserted into the profile

	<p>* 10 mm.lik çelik lama (Alm. cinsinden) atalet momenti: Ixx=16,0080cm⁴ Iyy= 1,0008cm⁴</p>	<p>* 10 mm flat steel (in aluminium) moment of inertia: Ixx=16,0080cm⁴ Iyy= 1,0008cm⁴</p>
--	----------------------------------------------------------------------------------------------------------------------------	-------------------------------------------------------------------------------------------------------------------------

KOD / CODE	AĞIRLIK (kg/m) / WEIGHT	Jxx cm ⁴	Jyy cm ⁴	L m	
ATS58V07	1,257	16,568	5,288	6	
ATS58V08	1,455	13,995	13,842	6	
ATS58V15	1,198	-----	-----	6	
ATS58V14	1,174	-----	-----	6	

ATS58V08

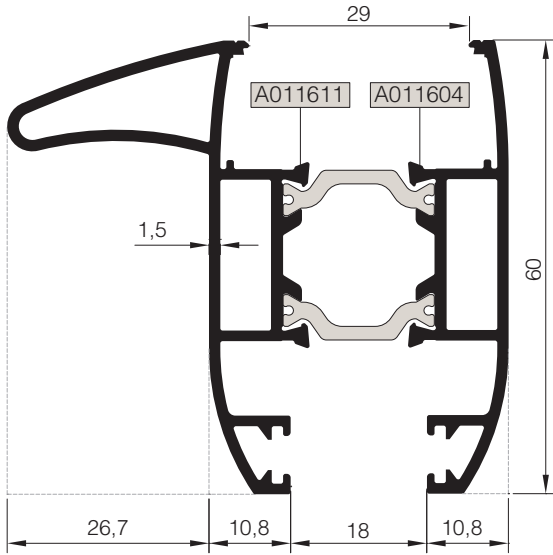

ATS58V07

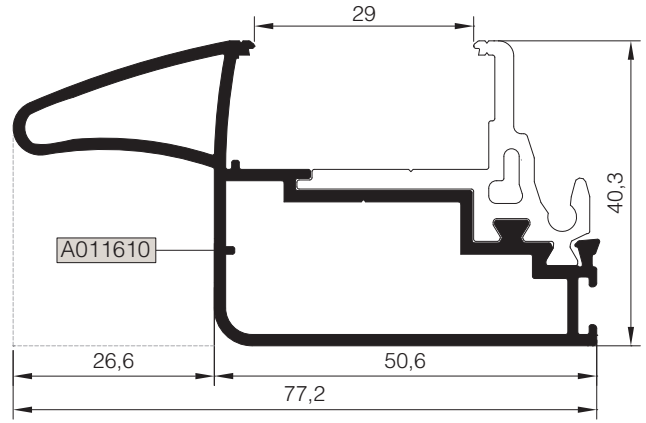

ATS58V14

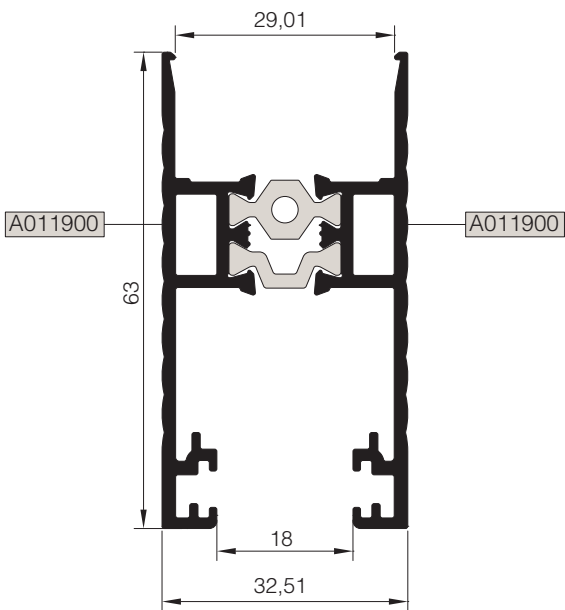

ATS58V15

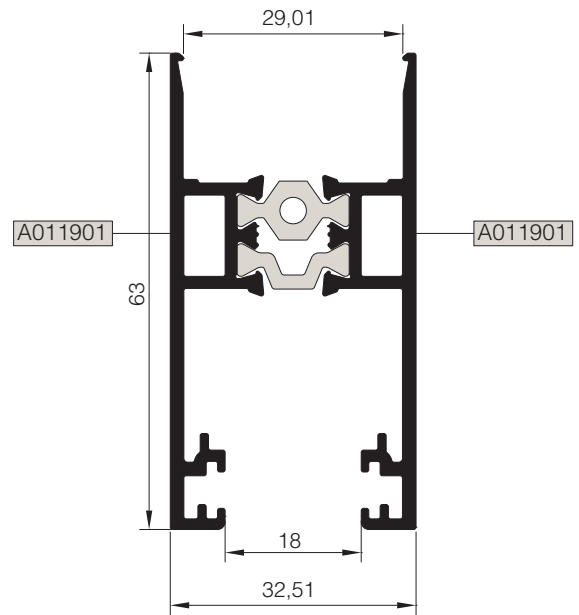

01

02

03

04

05

06

KOD / CODE	AĞIRLIK (kg/m) / WEIGHT	Jxx cm4	Jyy cm4	L m	
TS58 V 06	0,917	4,270	10,506	6	
ATS58V13	1,303	7,267	9,222	6	
TS58 A 05	0,525	----	----	6	
25 G 36	0,121	----	----	6	

TS58 V 06

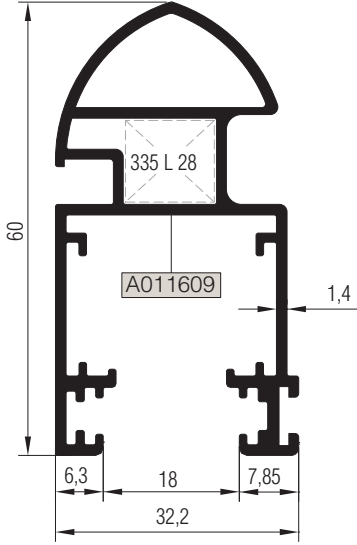

ATS58V13

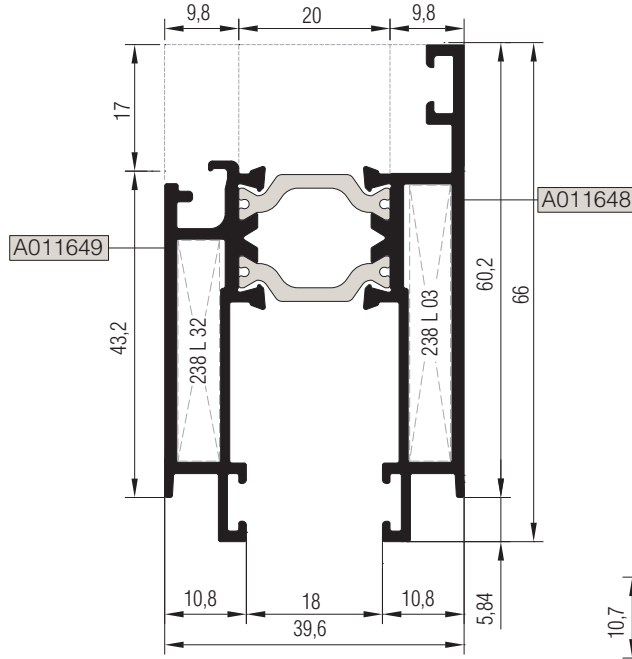

25 G 36

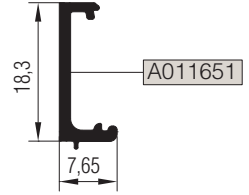

02.03.20
(6m. PVC Profil)

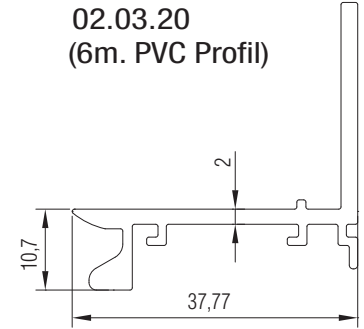

TS58 A 05

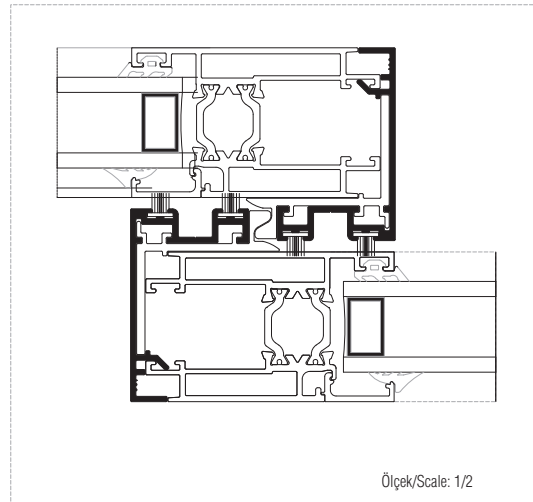
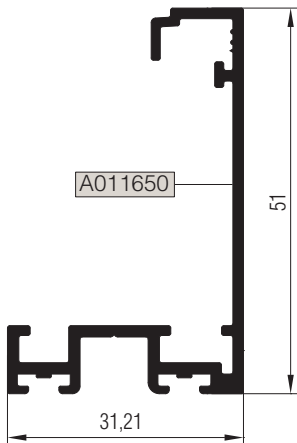

Nr		L m	KESİM ÖLÇÜSÜ CUTTING SIZE	AKS. KODU ACS. CODE
ATS58V13	A011649	25 L 32 (A002430)	5,5 mm	238 L 32
	A011648	25 L 03 (A002021)	5,5 mm	238 L 03
TS58 V 06	A011609	25 L 28 (A010542)	12,0 mm	335 L 28

KOD / CODE	AĞIRLIK (kg/m) / WEIGHT	Jxx cm ⁴	Jyy cm ⁴	L m
TS58 A 01	0,314	1,331	1,605	6
TS58 A 02	0,139	----	----	6
TS58 A 03	0,170	----	----	6
TS58 A 04	0,617	----	----	6
ATS58M01	0,901	4,270	3,041	6
T79 A 02	0,070	----	----	6
TS58 A 06	0,467	----	----	6

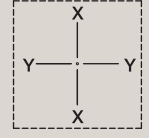

TS58 A 01

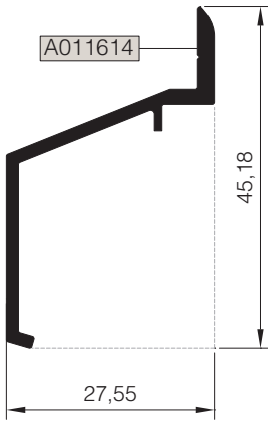

ATS58M01

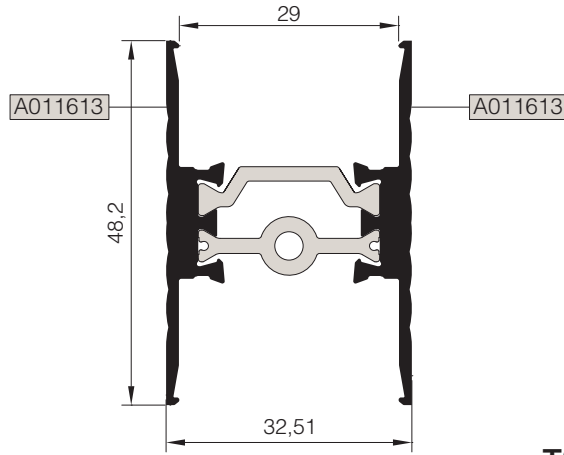

02.03.19
(6m. PVC Profil)

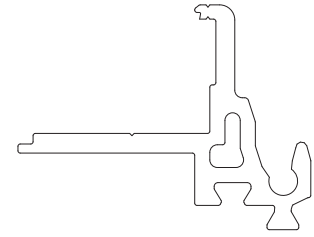

TS58 A 06

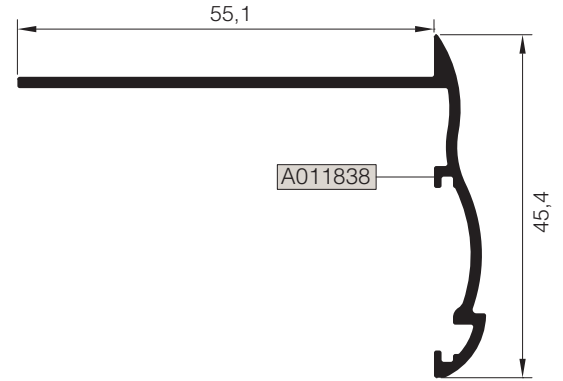

TS58 A 04

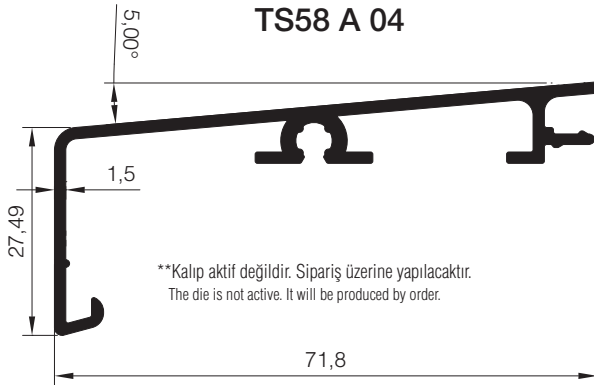

TS58 A 03

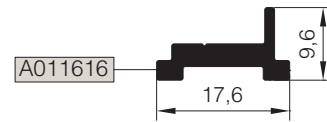

T79 A 02

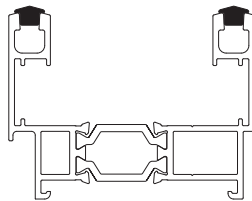
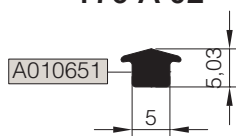

TS58 A 02

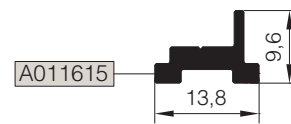

01

02

03

04

05

06

KÖŞE TAKOZLARI VE TİJ PROFİLLERİ

CORNER CLEATS AND ROD PROFILES

RST58

KOD / CODE	AĞIRLIK (kg/m) / WEIGHT	Jxx cm ⁴	Jyy cm ⁴	L m
25 I 06	0,104	----	----	6

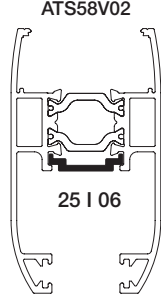
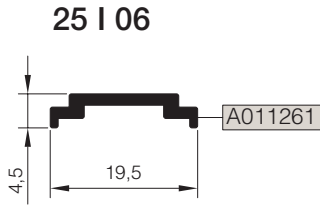
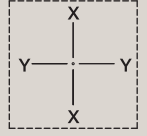

Ölçek / Scale: 1/2

PROFİL KODU (PROFILE CODE)	25 L 28	25 L 03	25 L 32
FABRİKA KODU (FACTORY CODE)	A010542	A002021	A002430
AĞIRLIK (WEIGHT)	3,689 kg/m	4,315 kg/m	3,702 kg/m
ÇİZİM (DRAWING)			

KÖŞE TAKOZLARI (CORNER CLEATS)				
Nr		L m	KESİM ÖLÇÜSÜ CUTTING SIZE	AKS. KODU ACS. CODE
ATS58F01	A011597	25 L 28 (A010542)	7,3 mm	318 L 28
	A011598	25 L 28 (A010542)	16,7 mm	319 L 28
ATS58F02	A011597	25 L 28 (A010542)	7,3 mm	318 L 28
	A011599	25 L 28 (A010542)	16,7 mm	319 L 28
ATS58F03	A011597	25 L 28 (A010542)	7,3 mm	318 L 28
	A011600	25 L 28 (A010542)	16,7 mm	319 L 28
ATS58F04	A011597	25 L 28 (A010542)	7,3 mm	318 L 28
	A011598	25 L 28 (A010542)	16,7 mm	319 L 28
	A011601	25 L 28 (A010542)	26,3 mm	320 L 28
ATS58F05	A011597	25 L 28 (A010542)	7,3 mm	318 L 28
	A011599	25 L 28 (A010542)	16,7 mm	319 L 28
	A011601	25 L 28 (A010542)	26,3 mm	320 L 28
ATS58F06	A011597	25 L 28 (A010542)	7,3 mm	318 L 28
	A011600	25 L 28 (A010542)	16,7 mm	319 L 28
	A011601	25 L 28 (A010542)	26,3 mm	320 L 28
ATS58F07	A011598	25 L 28 (A010542)	16,7 mm	319 L 28
	A011602	25 L 28 (A010542)	47,3 mm	321 L 28
ATS58F08	A011603	25 L 28 (A010542)	7,3 mm	318 L 28
	A011598	25 L 28 (A010542)	16,7 mm	319 L 28
ATS58F09	----	25 L 28 (A010542)	7,3 mm	318 L 28
	A011599	25 L 28 (A010542)	16,7 mm	319 L 28
ATS58F10	A011597	25 L 28 (A010542)	7,3 mm	318 L 28
	A011746	25 L 28 (A010542)	37,9 mm	173 L 28
ATS58F11	A011602	25 L 28 (A010542)	47,3 mm	321 L 28
	A011601	25 L 28 (A010542)	26,3 mm	320 L 28
	A011598	25 L 28 (A010542)	16,7 mm	319 L 28
ATS58V13	A011649	25 L 32 (A002430)	5,5 mm	238 L 32
	A011648	25 L 03 (A002021)	5,5 mm	238 L 03

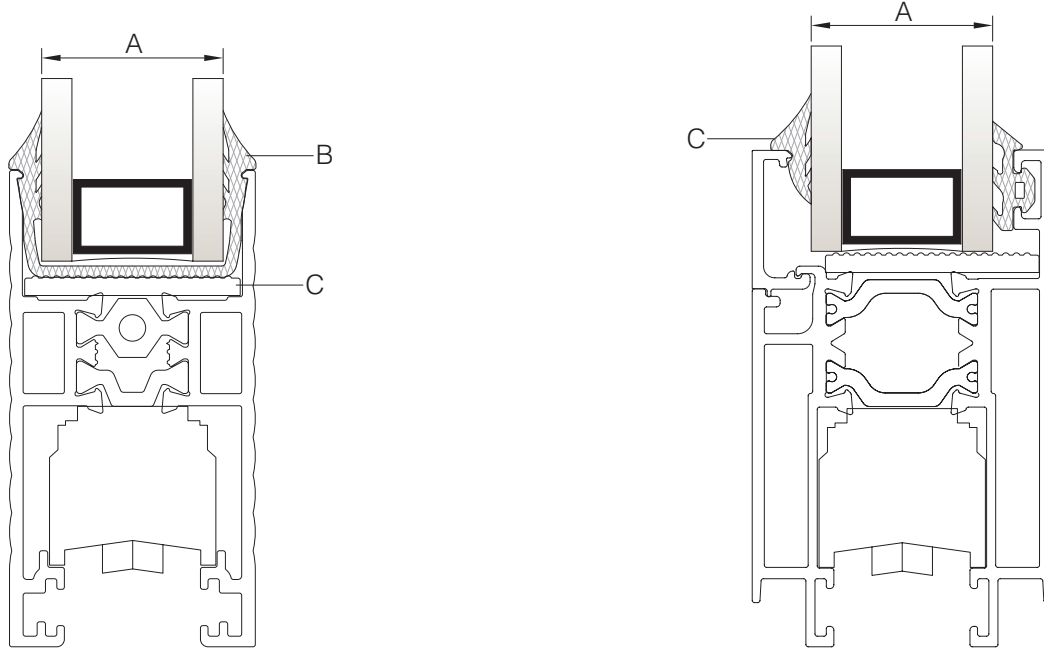

ÇİTALİ KANAT / VENT WITH GLAZING BEAD

U TİP FİTİL İÇİN CAM TABLOSU GLASS TABLE FOR U GASKET			
	-A- CAM KALINLIĞI GLASS THICKNESS	-B- CAM FİTİLİ GLAZING GASKET	-C- CAM TAKOZU GLASS SUPPORT
1	20 mm	01.16.18	11.02.20
2	22 mm	01.16.17	11.02.20
3	24 mm	01.16.16	11.02.20

KAMA TİP FİTİL İÇİN CAM KALINLIKLARI TABLOSU GLASS TABLE FOR GLAZING GASKET				
	-A- CAM KALINLIĞI GLASS THICKNESS	-C- DIŞ CAM FİTİLİ OUTER GLAZING GASKET	-D- İÇ CAM FİTİLİ INNER GLAZING GASKET	-E- CAM TA KOZU GLASS SUPPORT
1	24 mm	01.16.19	01.17.08	11.02.20
2	22 mm	01.16.19	01.17.23	11.02.20

01

02

03

04

05

06

STOKTA BULUNAN SİSTEM PROFİLLERİNİN LİSTESİ (LIST OF SYSTEM PROFILES IN STOCK)

Nr			MIN. SİPARİŞ MİKTARI MIN. ORDER QUANTITY
ATS58F01	A011597	75 kg	150 kg
	A011598	75 kg	
ATS58F02	A011597	75 kg	150 kg
	A011599	75 kg	
ATS58F03	A011597	75 kg	150 kg
	A011600	75 kg	
ATS58F04	A011597	75 kg	150 kg
	A011598	75 kg	
ATS58F07	A011602	75 kg	150 kg
	A011598	75 kg	
ATS58V01	A011604	75 kg	150 kg
	A011604	75 kg	
ATS58V02	A011605	75 kg	150 kg
	A011605	75 kg	
ATS58V09	A011612	75 kg	150 kg
	A011612	75 kg	
ATS58V13	A011648	75 kg	150 kg
	A011649	75 kg	
ATS58V14	A011900	75 kg	150 kg
	A011900	75 kg	
ATS58V15	A011901	75 kg	150 kg
	A011901	75 kg	
TS58 V 06	A011609	75 kg	
TS58 V 10	A011607	75 kg	
TS58 V 11	A011610	75 kg	
TS58 V 12	A011606	75 kg	
TS58 A 05	A011650	75 kg	

* STOKTA BULUNMAYAN TÜM PROFİLLER İÇİN MINİMUM SİPARİŞ MİKTARI 300'KG'DİR.
MINIMUM ORDER QUANTITY FOR ALL THE PROFILES THAT ARE NOT IN STOCK IS 300 KG.

MİMARİ KATALOG

ARCHITECTURAL CATALOGUE

Alüminyum Kapı Pencere ve Giydirme Cephe Sistemleri
Aluminium Door Window and Facade Systems

RST58

DETAYLAR

DETAILS

01

02

03

04

05

06

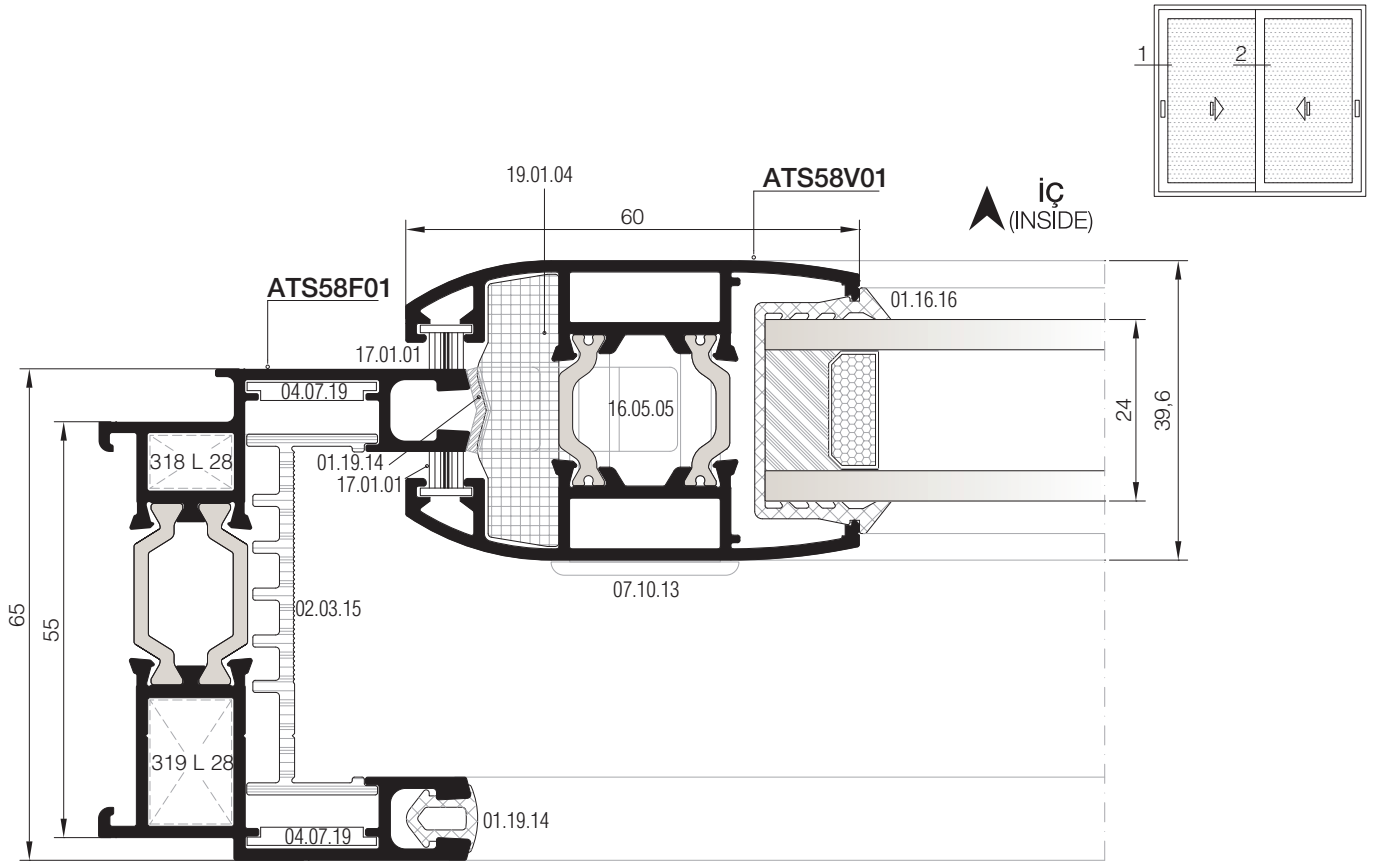

1 DETAYI
DETAIL

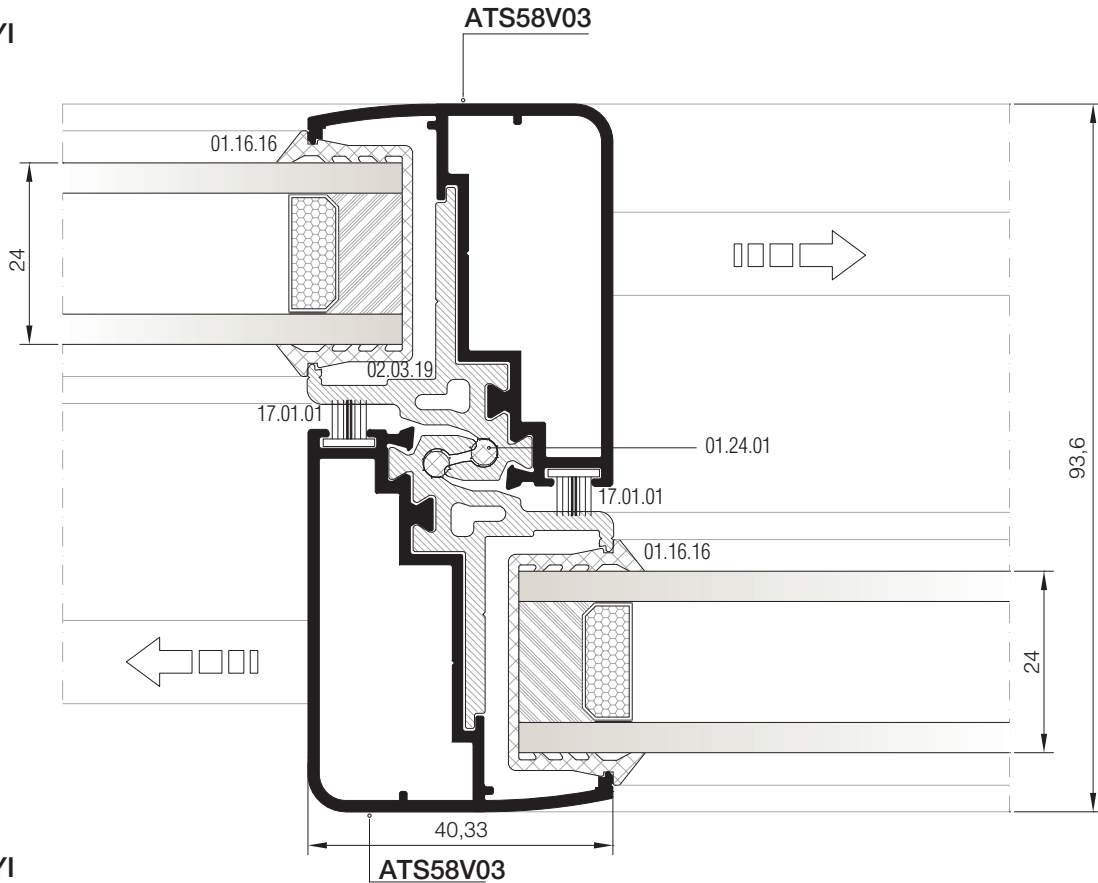

2 DETAYI
DETAIL

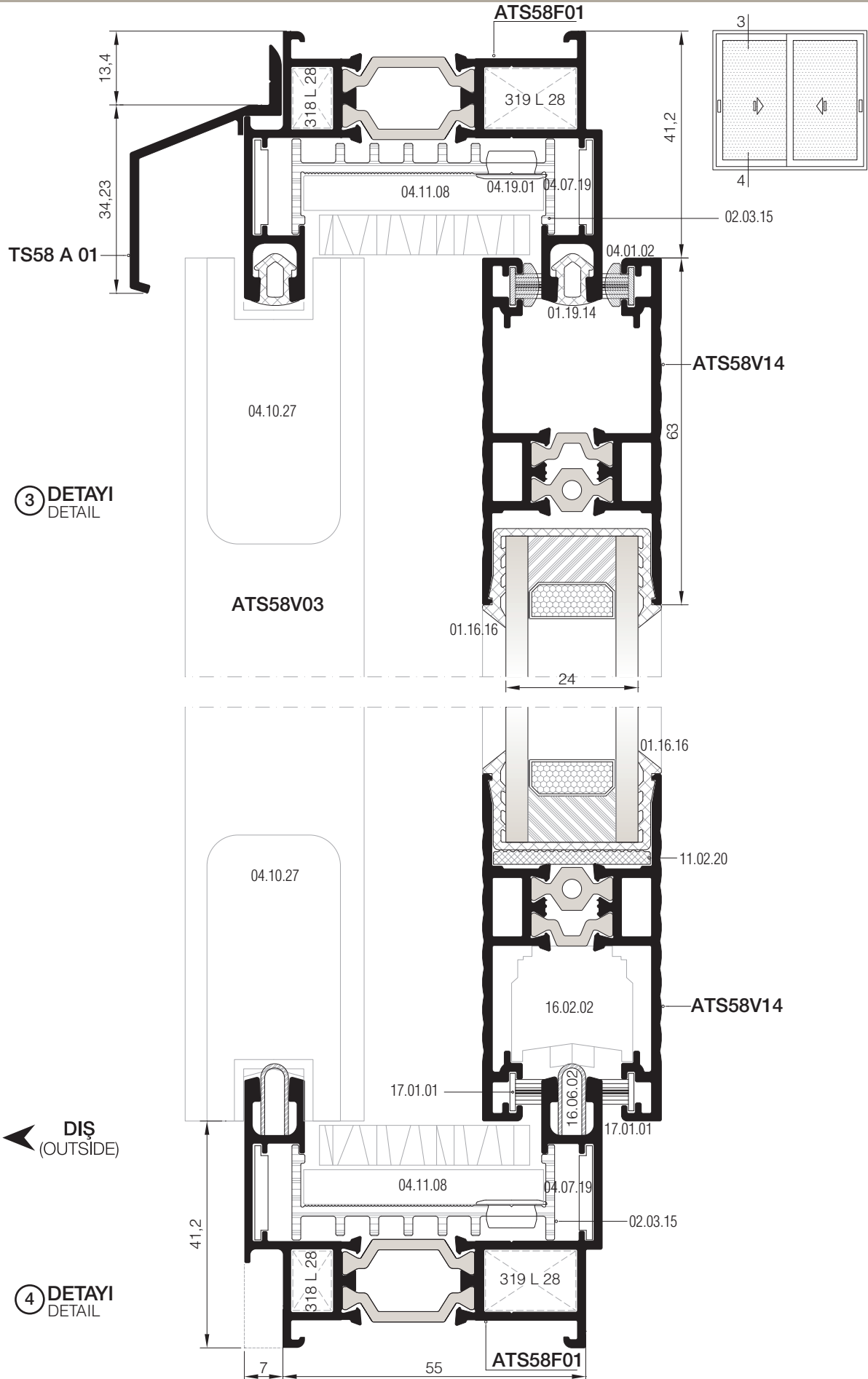

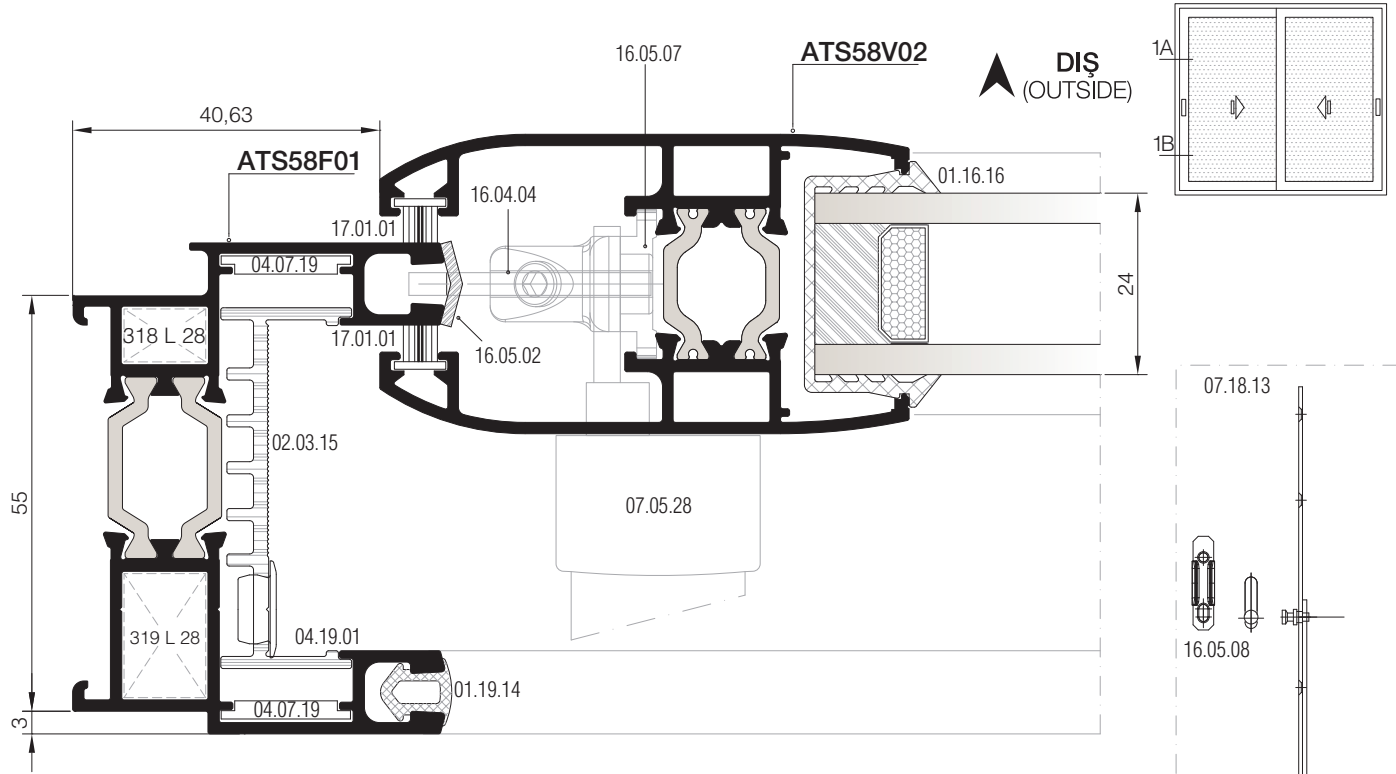

1A DETAYI
DETAIL

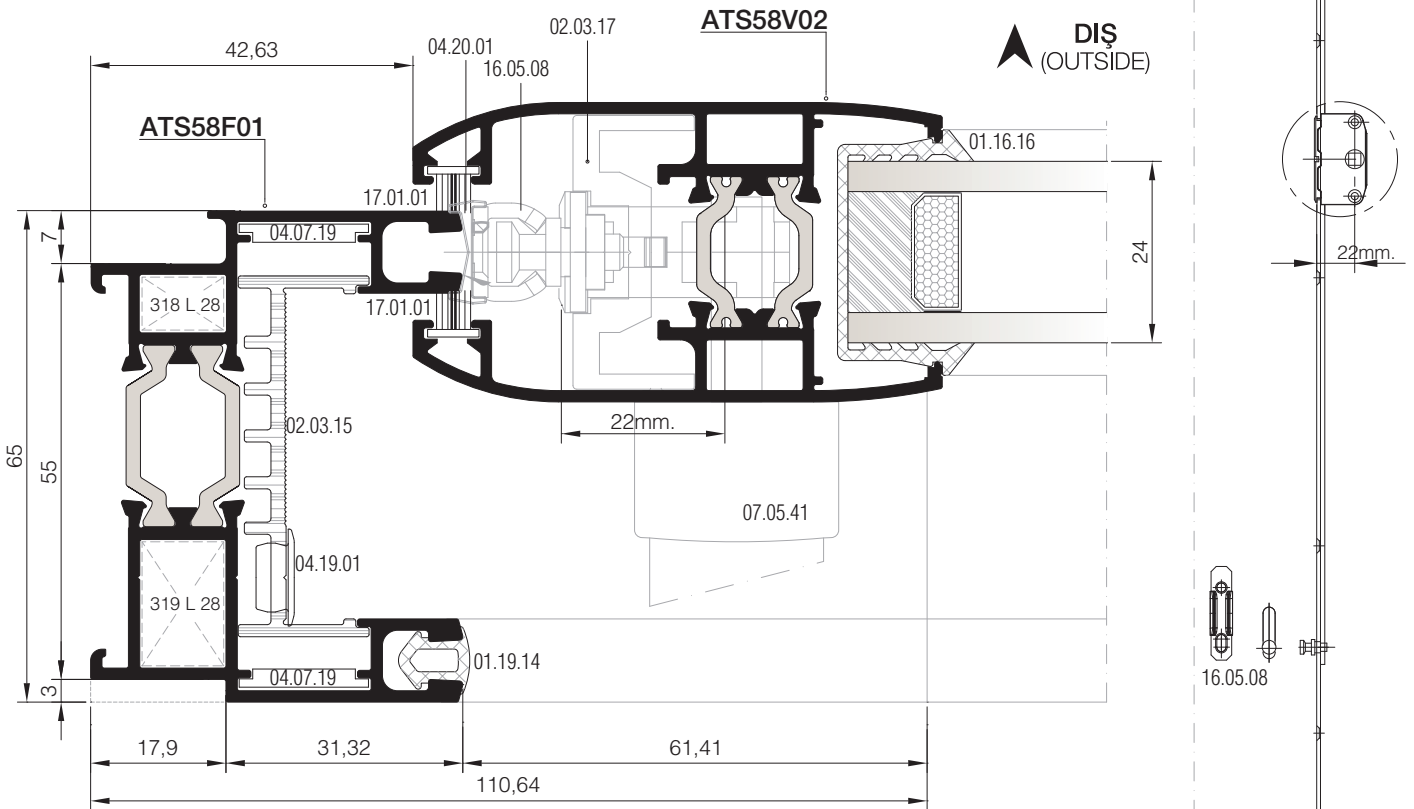

1B DETAYI
DETAIL

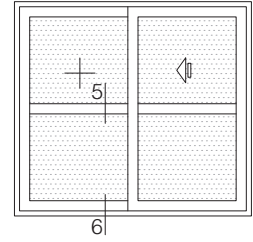

5 DETAYI
DETAIL

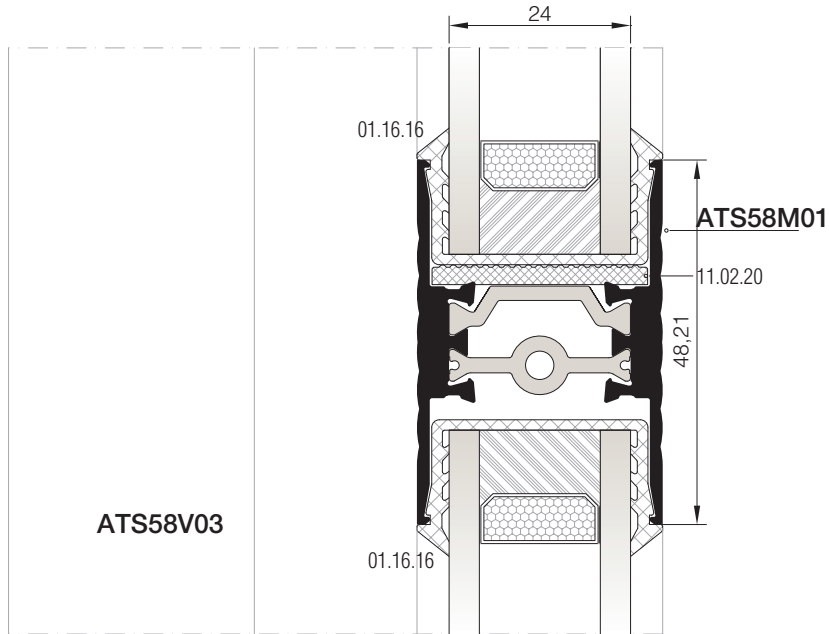

01

02

03

04

05

06

6 DETAYI
DETAIL

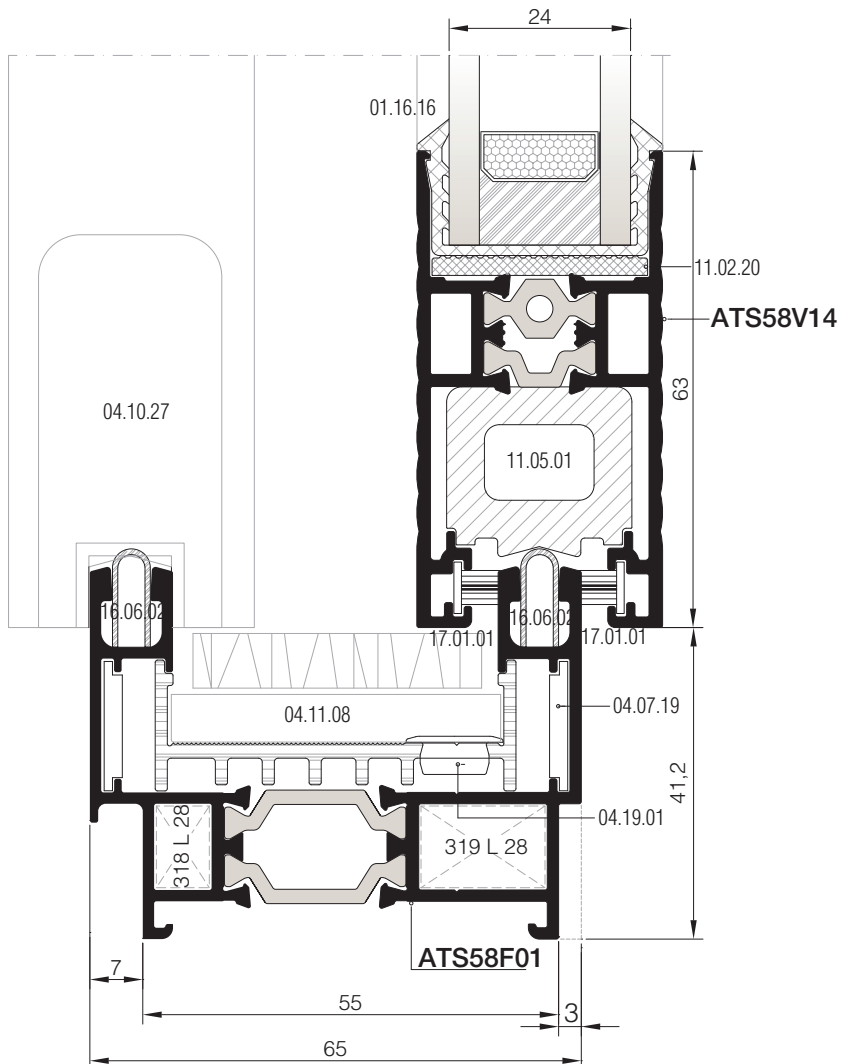

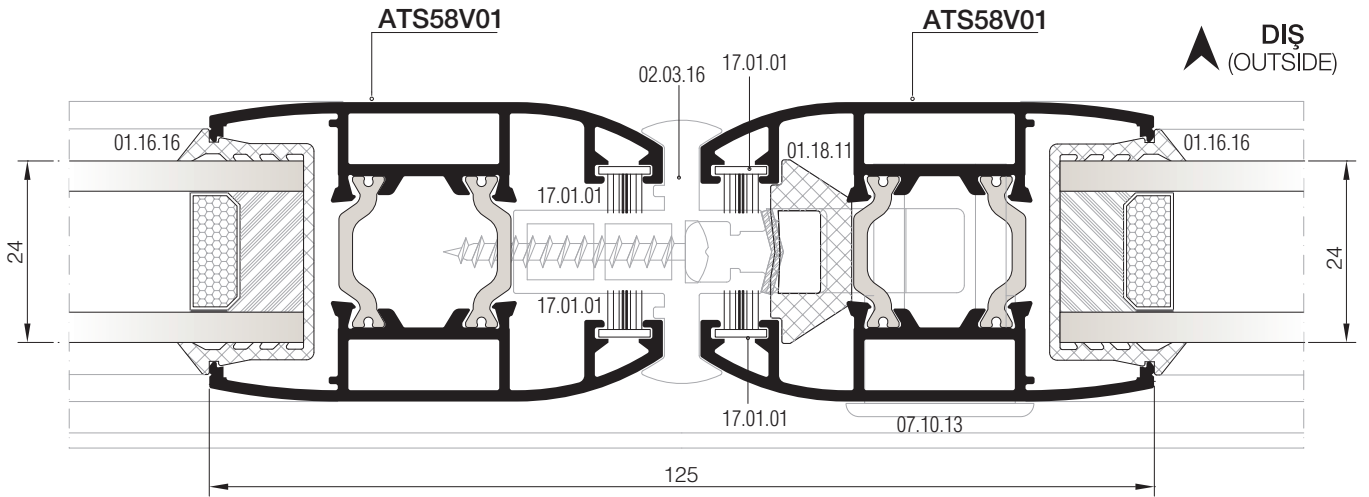
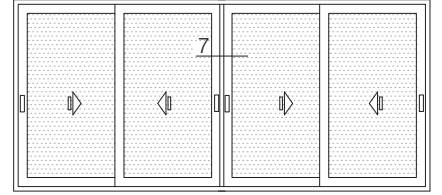

7 DETAYI
DETAIL

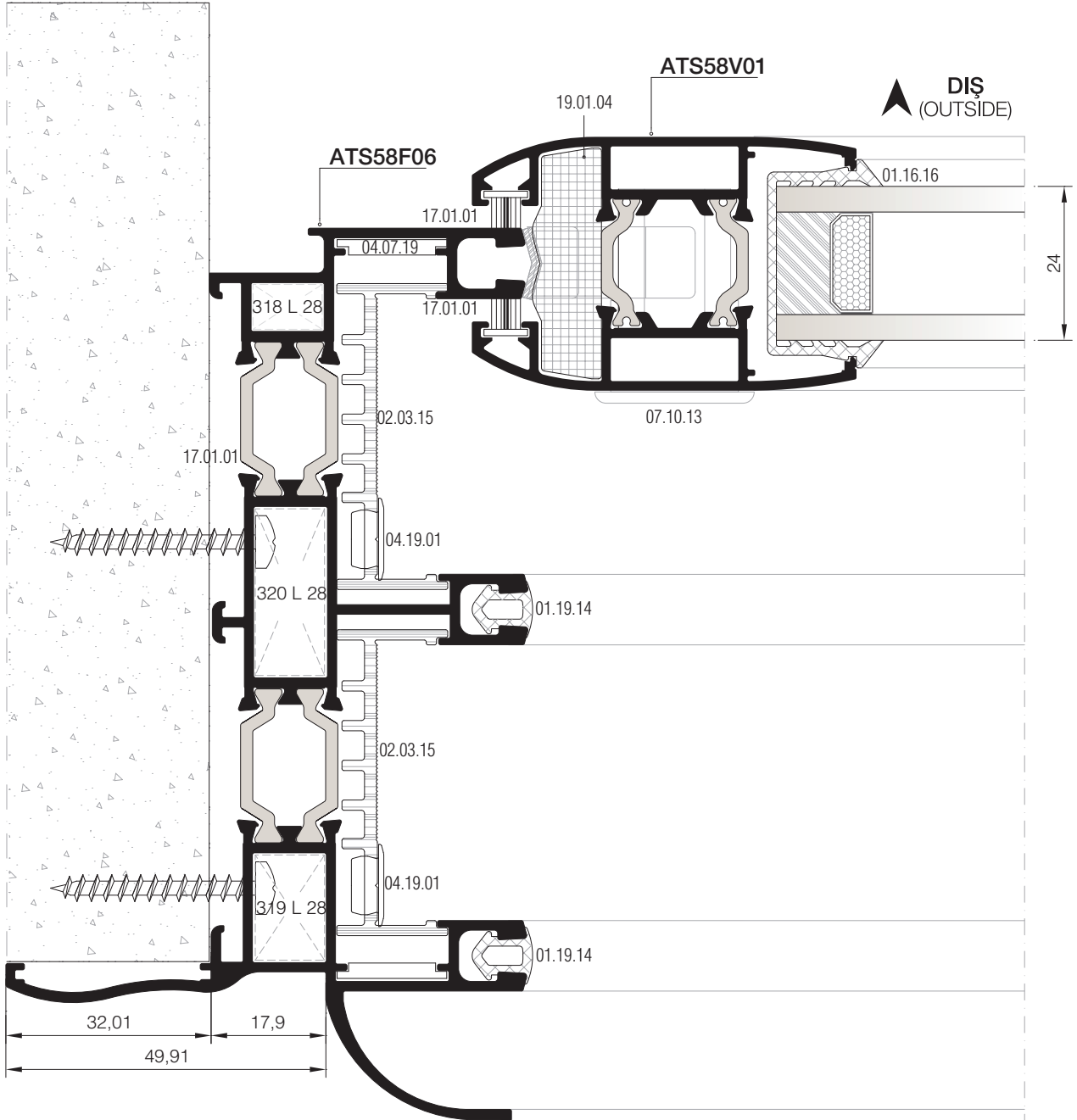
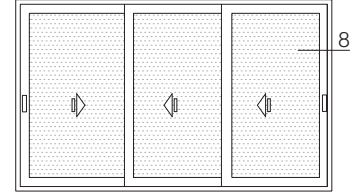

01

02

03

04

05

06

8 DETAYI
DETAIL

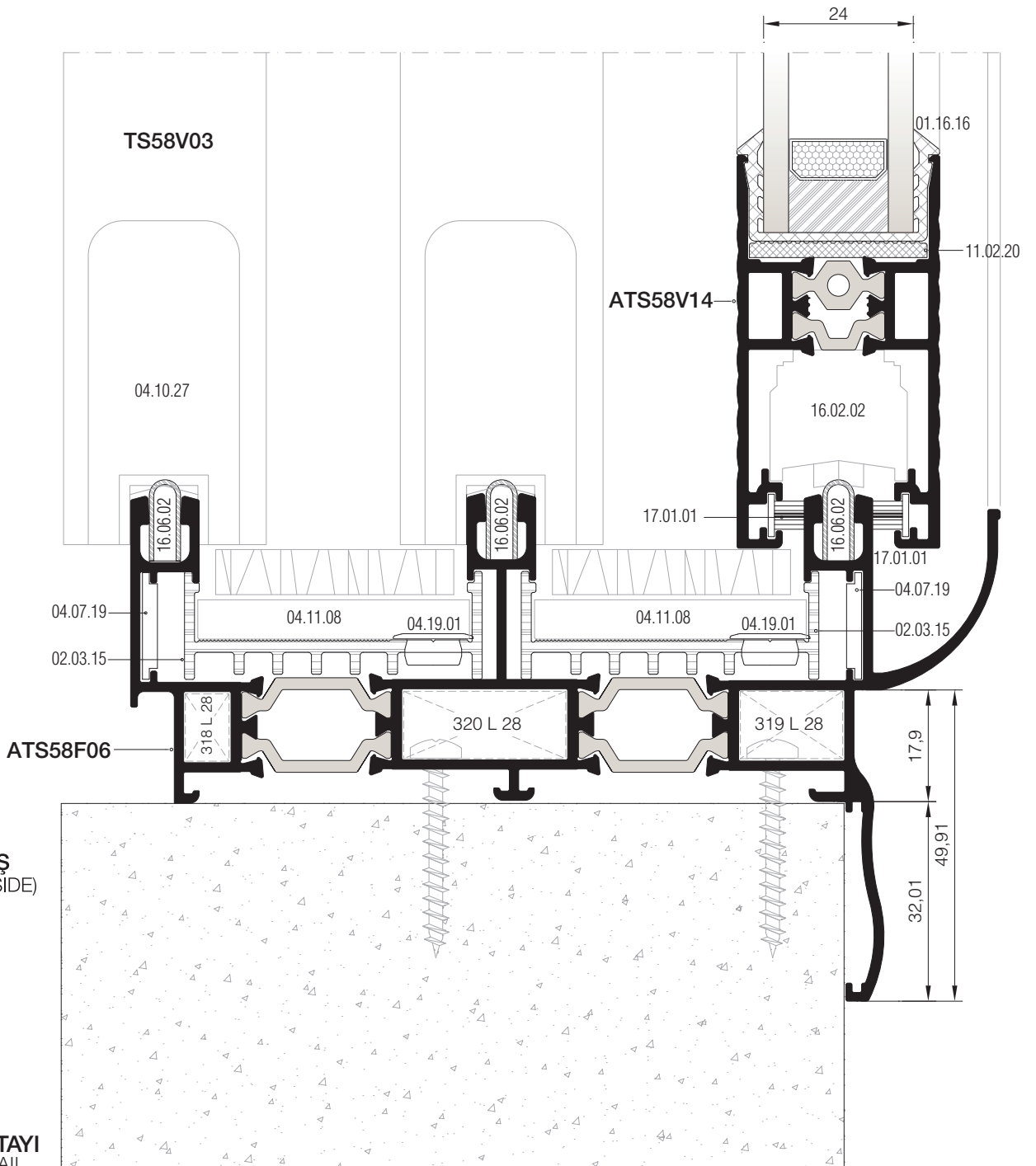
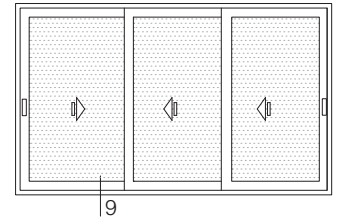

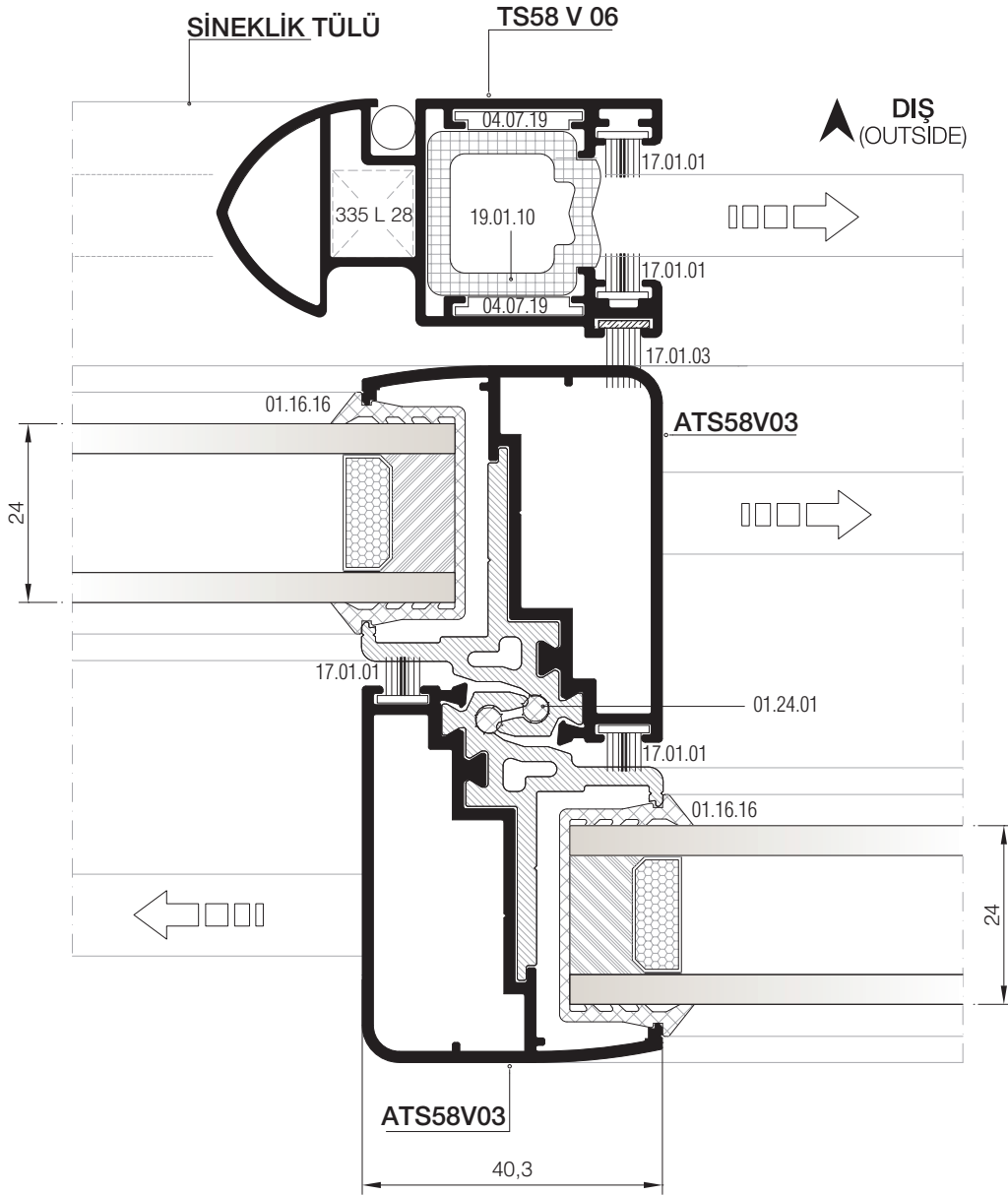
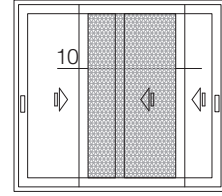

10 DETAYI
DETAIL

01

02

03

04

05

06

- 01
- 02
- 03
- 04
- 05
- 06

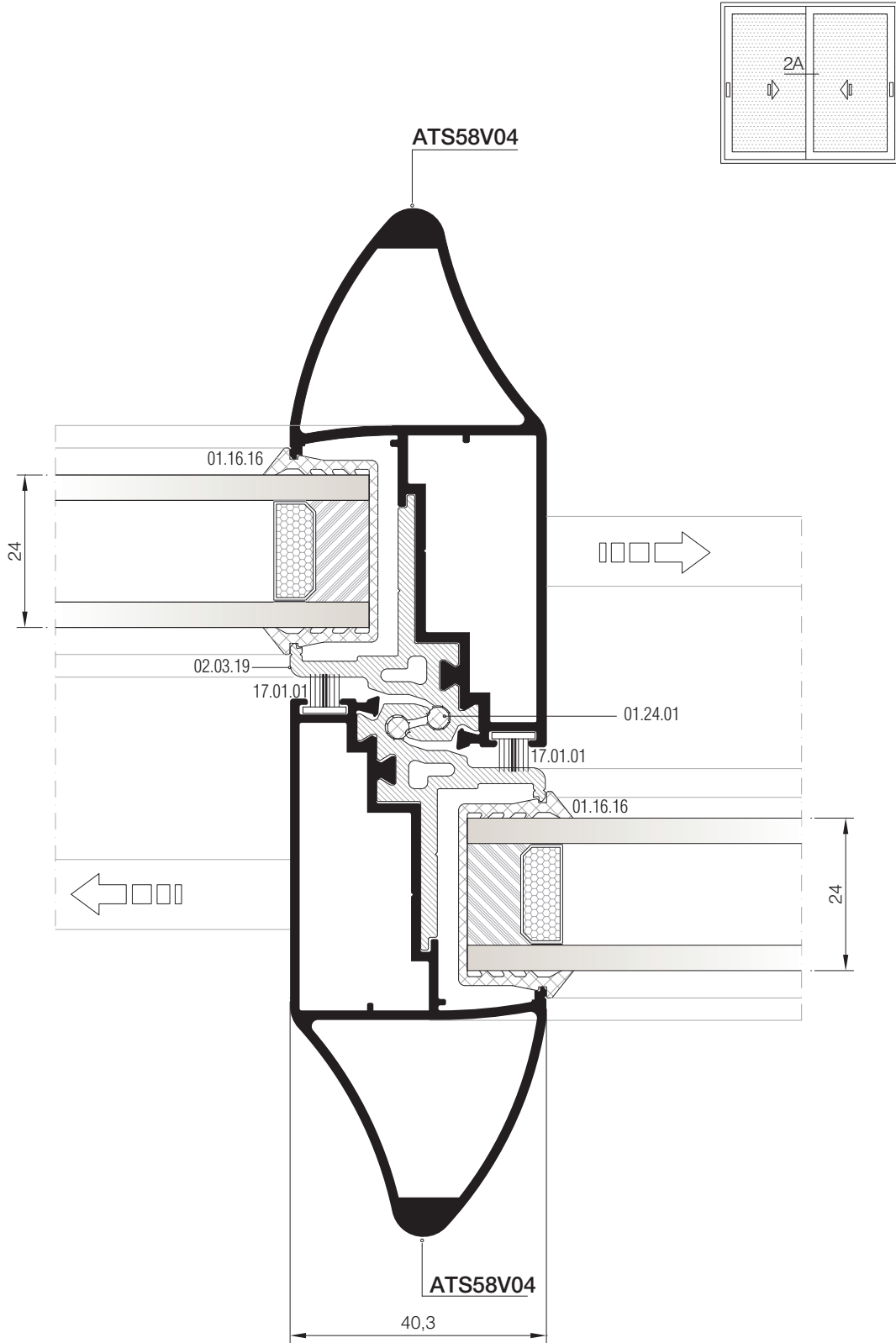

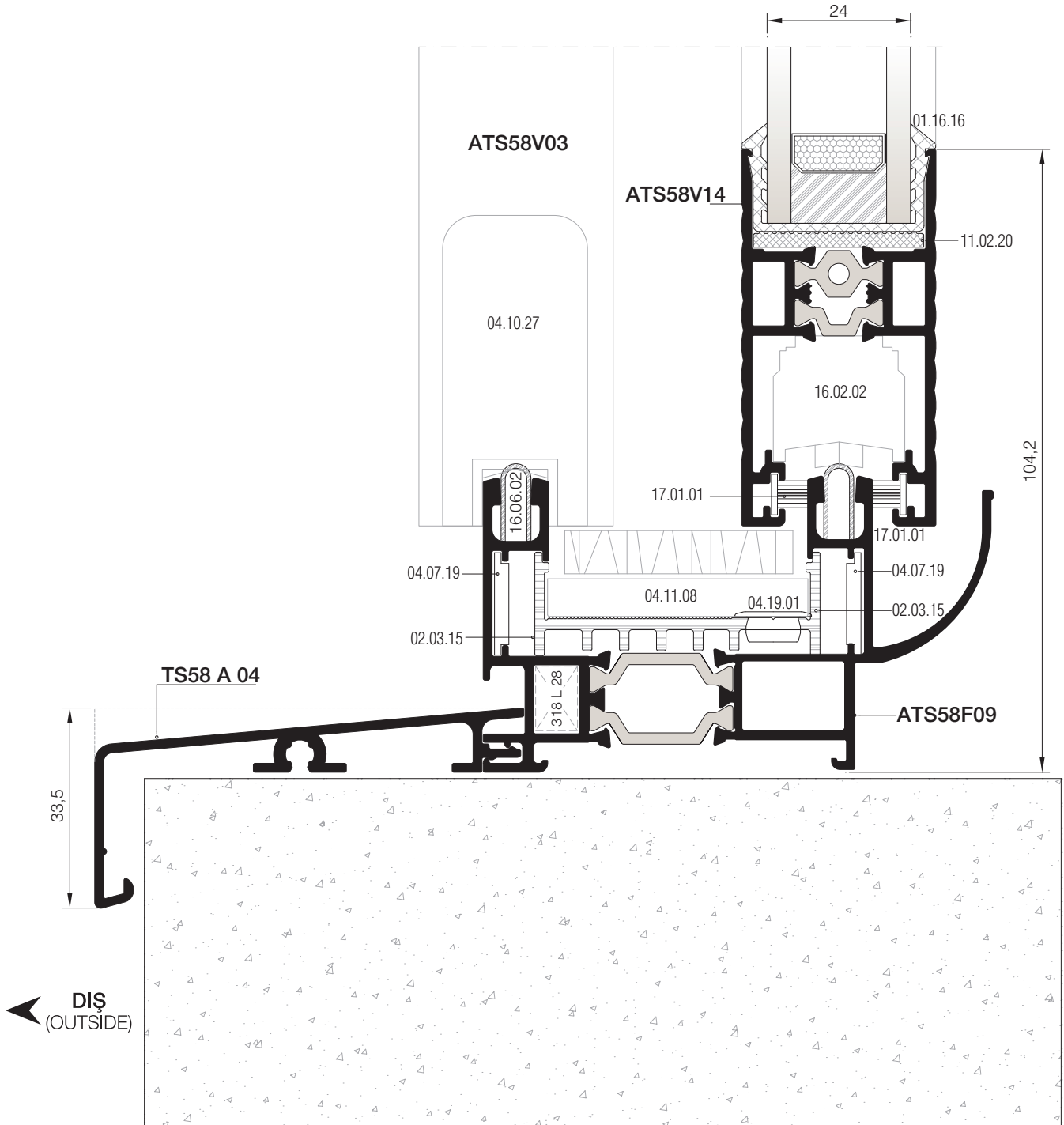
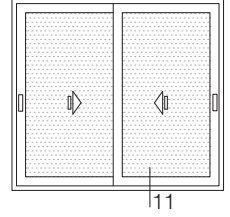

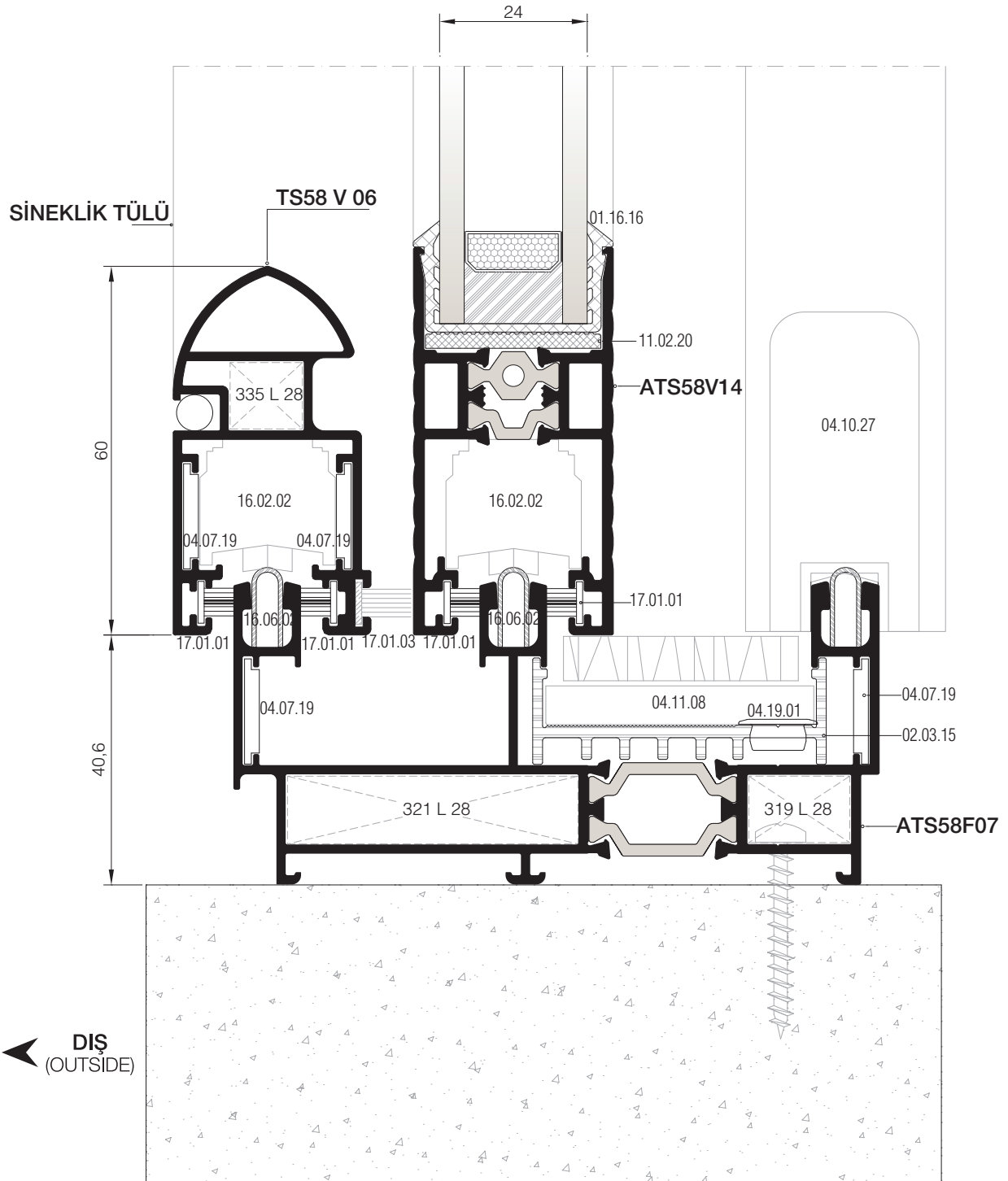
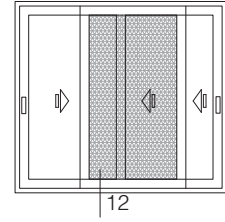

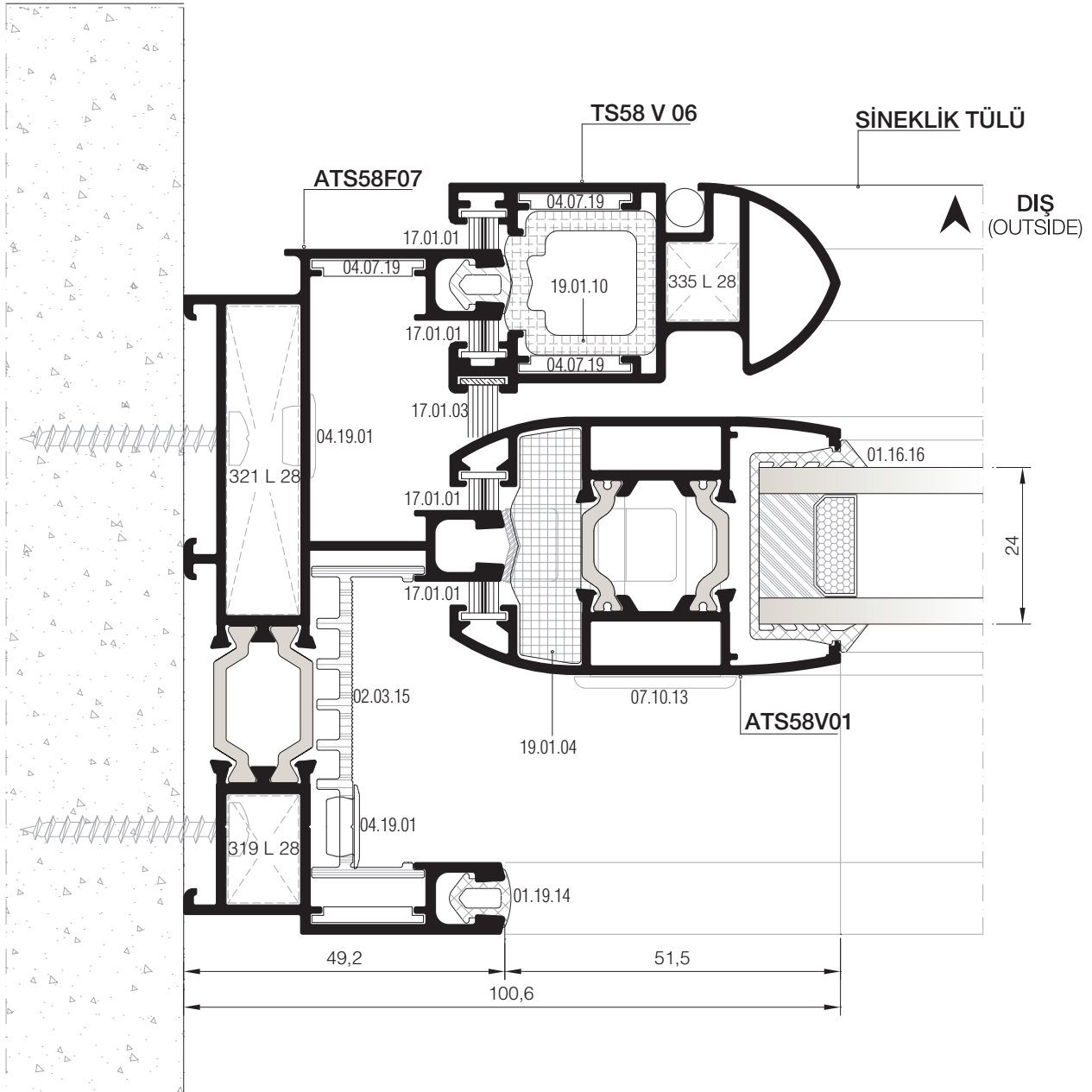
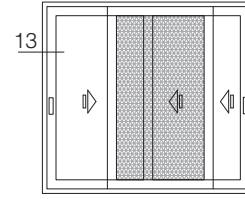

13 DETAYI
DETAIL

01

02

03

04

05

06

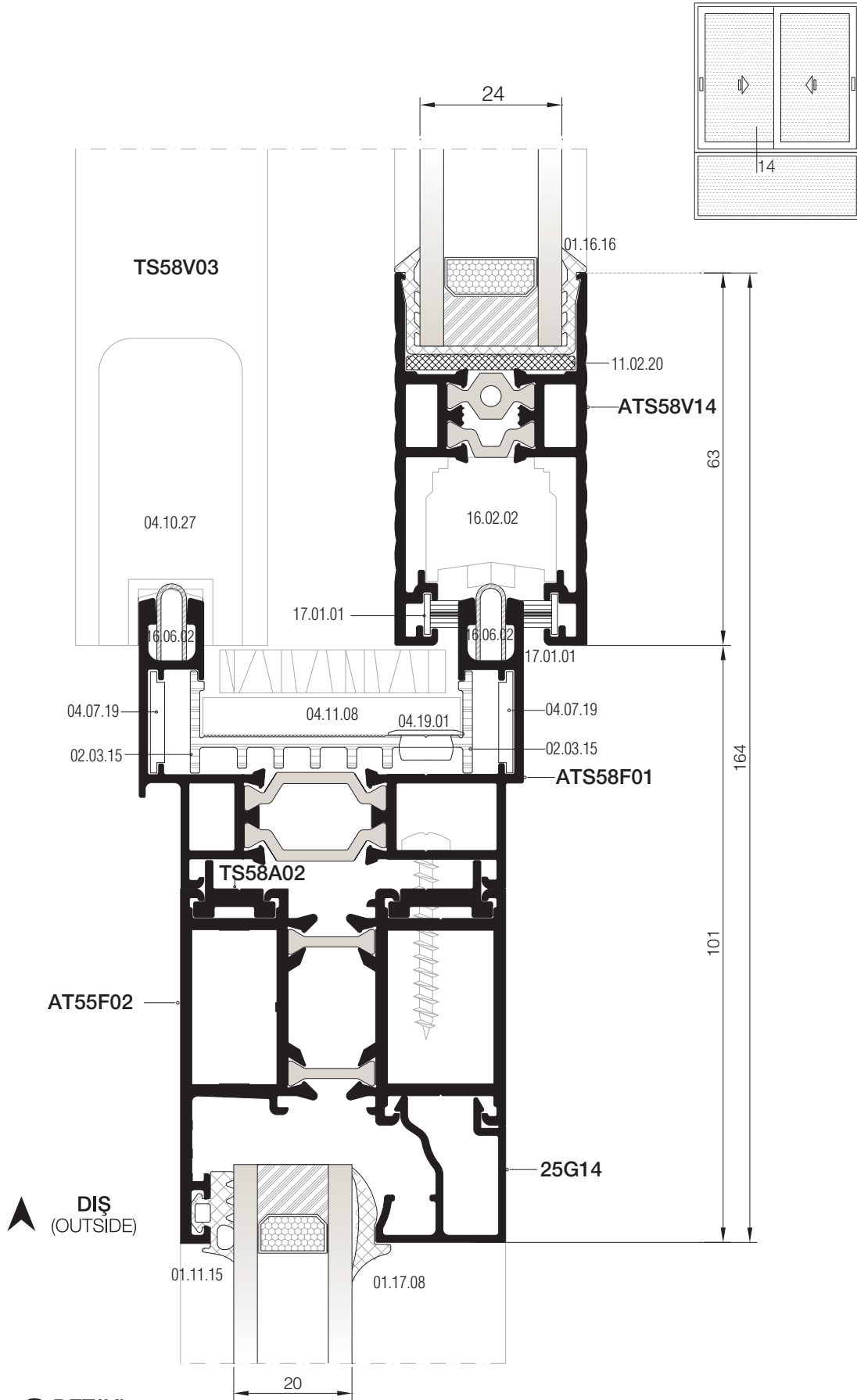

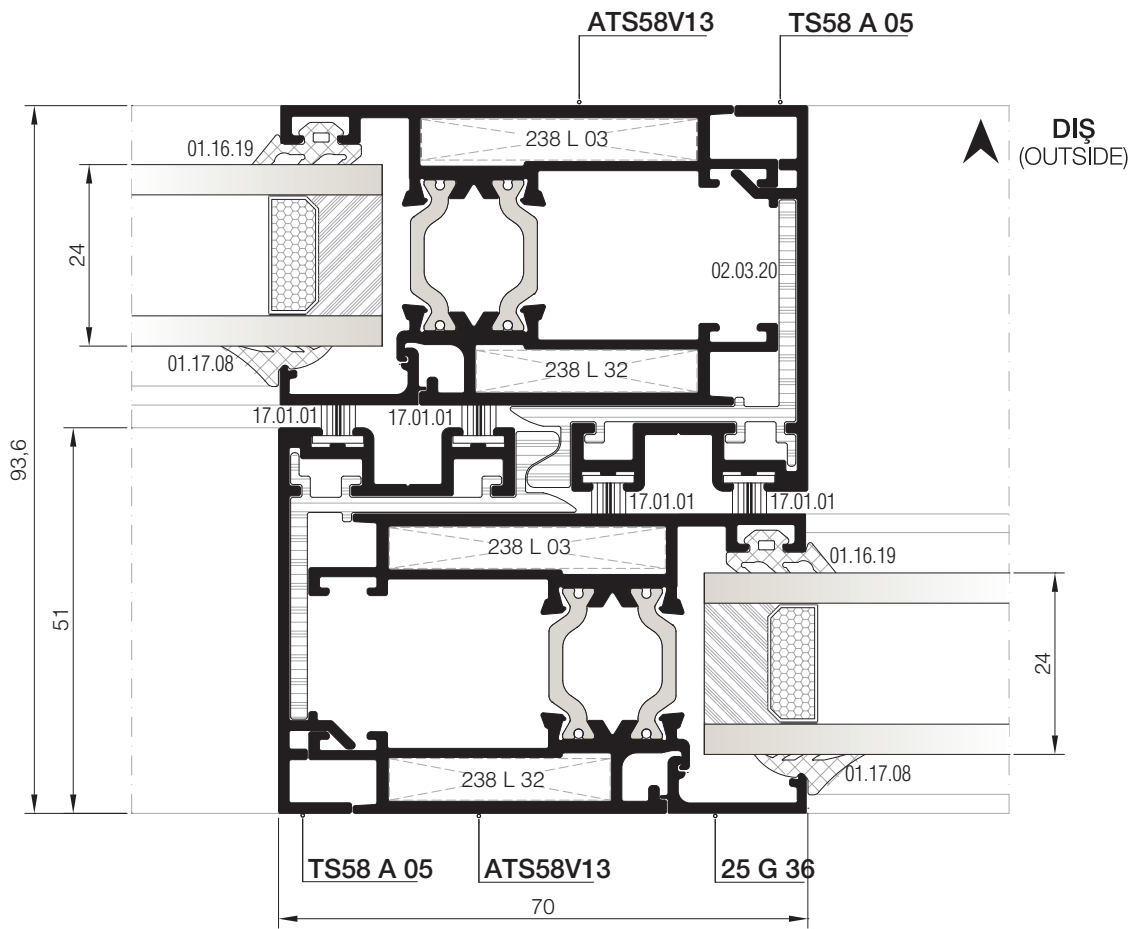
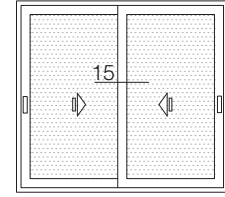

15 DETAYI
DETAIL

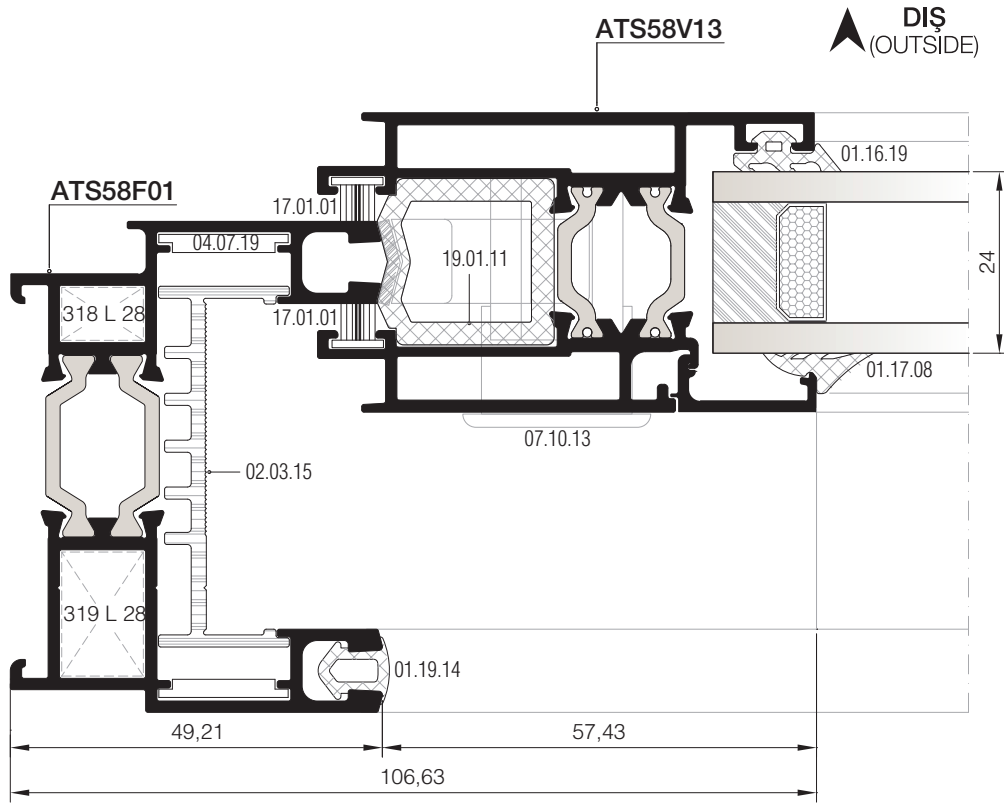
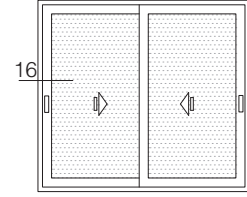

16 DETAYI
DETAIL

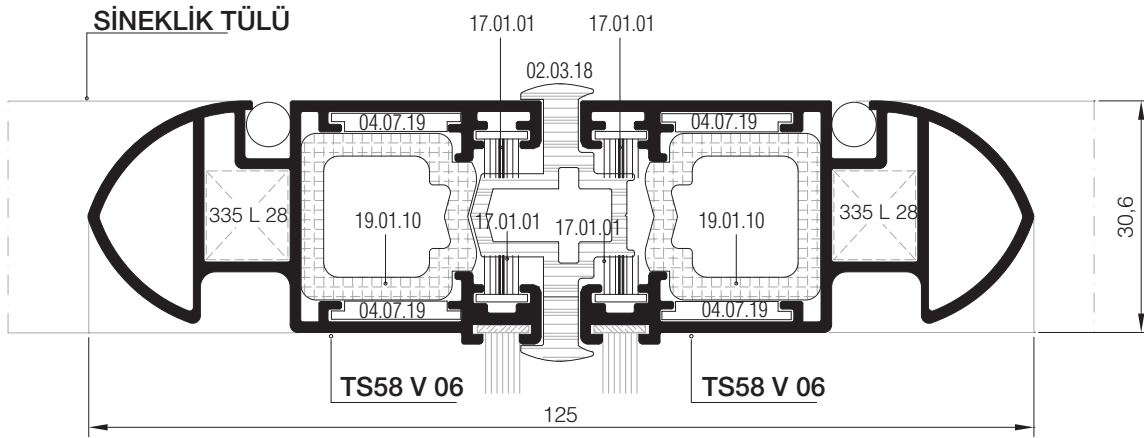
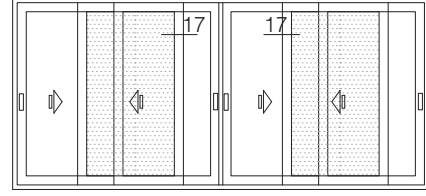

17 DETAYI
DETAIL

01

02

03

04

05

06

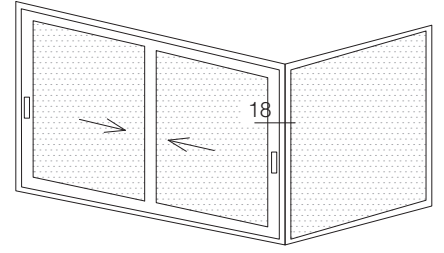

- 01
- 02
- 03
- 04
- 05
- 06

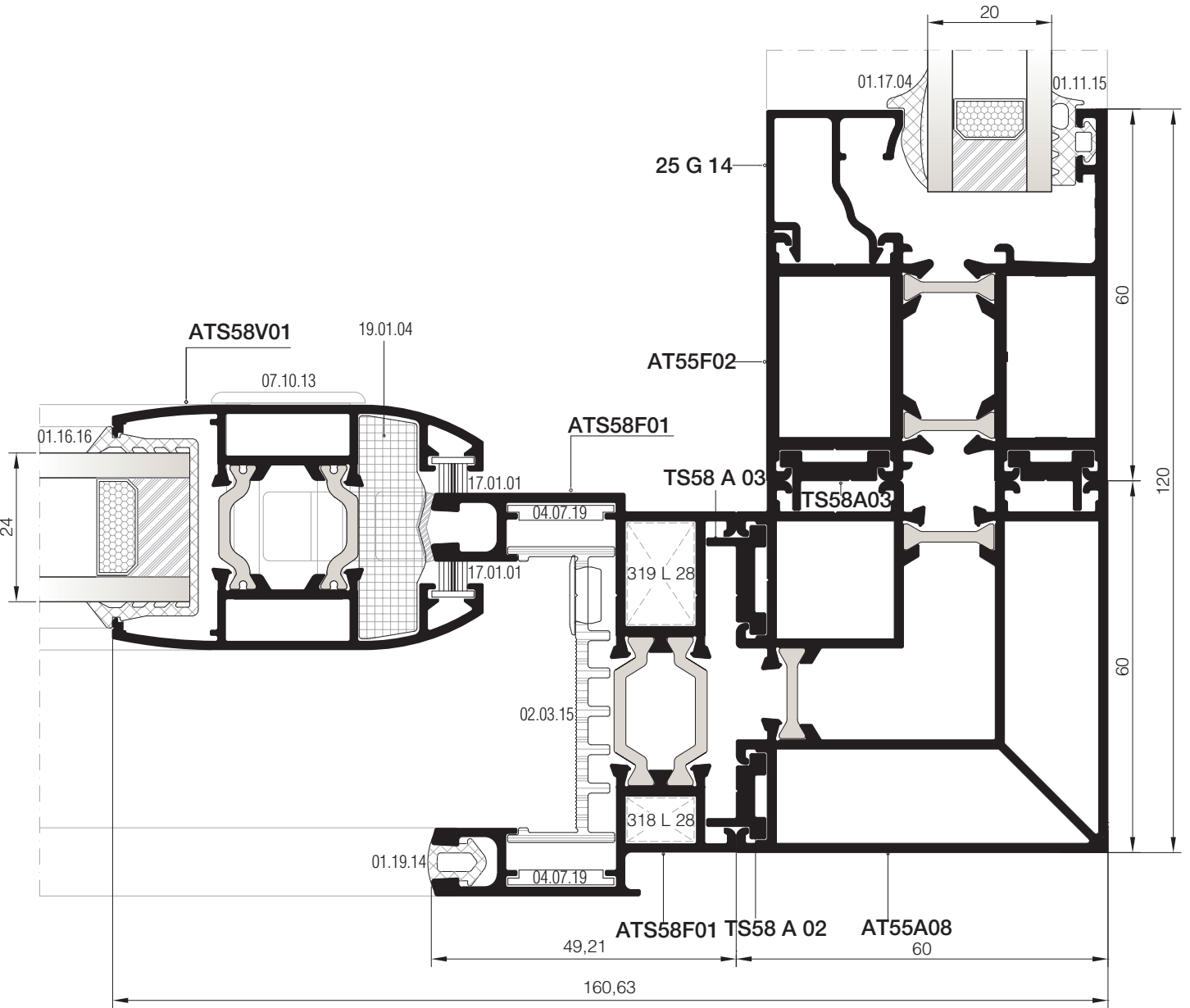

18 DETAYI
DETAIL

DIŞ
(OUTSIDE) ➔

MİMARİ KATALOG

ARCHITECTURAL CATALOGUE

Alüminyum Kapı Pencere ve Giydirme Cephe Sistemleri
Aluminium Door Window and Facade Systems

RST58

AKSESUARLAR

ACCESSORIES

01

02

03

04

05

06

	<p>01.16.16</p> <p>U TİPİ CAM FİTİLİ GLAZING GASKET</p> <p>Malzeme / Material: EPDM Ağırlık / Weight: 156 gr/m Paket / Package: 96 m / 15 kg</p>			<p>01.18.11</p> <p>ORTA BASMA FİTİLİ CENTRAL GASKET</p> <p>Malzeme / Material: EPDM Ağırlık / Weight: 208 gr/m Paket / Package: 72 m / 15 kg</p>	
01	<p>01.16.17</p> <p>U TİPİ CAM FİTİLİ GLAZING GASKET</p> <p>Malzeme / Material: EPDM Ağırlık / Weight: 200 gr/m Paket / Package: 75 m / 15 kg</p>			<p>01.19.14</p> <p>RAY FİTİLİ RAIL COVER GASKET</p> <p>Malzeme / Material: EPDM Ağırlık / Weight: 52 gr/m Paket / Package: 288 m / 15 kg</p>	
02	<p>01.16.18</p> <p>U TİPİ CAM FİTİLİ GLAZING GASKET</p> <p>Malzeme / Material : EPDM Ağırlık / Weight : 238 gr/m Paket / Package : 63 m / 15 kg</p>			<p>01.24.01</p> <p>KENET FİTİLİ CONNECTION GASKET</p> <p>Malzeme / Material: EPDM Ağırlık / Weight: 10 gr/m Paket / Package: 1500 m / 15 kg</p>	
03	<p>01.17.08</p> <p>KAMA TİPİ CAM FİTİLİ GLAZING GASKET</p> <p>Malzeme / Material: EPDM Ağırlık / Weight: 51 gr/m Paket / Package: 294 m / 15 kg</p> <p>2,5mm</p>			<p>04.11.08</p> <p>SIZDIRMAZLIK PARÇASI SEALING PART</p> <p>Malzeme / Material: EPDM</p>	
04	<p>01.17.22</p> <p>KAMA TİPİ CAM FİTİLİ GLAZING GASKET</p> <p>Malzeme / Material: EPDM Ağırlık / Weight: 51 gr/m Paket / Package: 294 m / 15 kg</p> <p>3,5mm</p>			<p>17.01.01</p> <p>KİL FİTİL 670x700 BRUSH 670x700</p> <p>Malzeme / Material: Polipropilen / Polipropilene Paket / Package: 275 mt</p>	
05	<p>01.17.23</p> <p>KAMA TİPİ CAM FİTİLİ GLAZING GASKET</p> <p>Malzeme / Material: EPDM Ağırlık / Weight: 63 gr/m Paket / Package: 238 m / 15 kg</p> <p>4,5mm</p>			<p>17.01.03</p> <p>KİL FİTİL 670X1000 BRUSH 670X1000</p> <p>Malzeme / Material: Polipropilen / Polipropilene</p>	
06	<p>01.16.19</p> <p>DIŞ CAM FİTİLİ GLAZING GASKET</p> <p>Malzeme / Material: EPDM Ağırlık / Weight: 68 gr/m Paket / Package: 220 m / 15 kg</p> <p>2,8mm</p>				

	<p>04.01.02 KANAT SABİTLEYİCİ FIXED VENT Malzeme / Material: PVC (15 mm)</p>			<p>04.10.28A PVC KAPAK PVC CAP Malzeme / Material: PVC (ATS58V07 için / for ATS58V07) 04.10.28A ve 04.10.28B birlikte kullanılacaktır. / 04.10.28A and 04.10.28B will be used together.</p>	
	<p>04.07.19 KÖŞE ÇAVUŞU CORNER CLEAT Malzeme / Material: PVC</p>			<p>04.10.28B PVC KAPAK PVC CAP Malzeme / Material: PVC (ATS58V07 için / for ATS58V07) 04.10.28A ve 04.10.28B birlikte kullanılacaktır. / 04.10.28A and 04.10.28B will be used together.</p>	
	<p>04.10.24 PVC KAPAK PVC CAP Malzeme / Material: PVC (ATS58V01 için / for ATS58V01)</p>			<p>04.10.29A PVC KAPAK PVC CAP Malzeme / Material: PVC (ATS58V04 için / for ATS58V04) 04.10.29A ve 04.10.29B birlikte kullanılacaktır. / 04.10.29A and 04.10.29B will be used together.</p>	
	<p>04.10.25 PVC KAPAK PVC CAP Malzeme / Material: PVC (ATS58V02 için / for ATS58V02)</p>			<p>04.10.29B PVC KAPAK PVC CAP Malzeme / Material: PVC (ATS58V04 için / for ATS58V04) 04.10.29A ve 04.10.29B birlikte kullanılacaktır. / 04.10.29A and 04.10.29B will be used together.</p>	
	<p>04.10.26A PVC KAPAK PVC CAP Malzeme / Material: PVC (ATS58V08 için / for ATS58V08)</p>			<p>04.10.30A PVC KAPAK PVC CAP Malzeme / Material: PVC (ATS58V03 için / for ATS58V03) 04.10.30A ve 04.10.30B birlikte kullanılacaktır. / 04.10.30A and 04.10.30B will be used together.</p>	
	<p>04.10.26B PVC KAPAK PVC CAP Malzeme / Material: PVC (ATS58V08 için / for ATS58V08)</p>			<p>04.10.30B PVC KAPAK PVC CAP Malzeme / Material: PVC (ATS58V03 için / for ATS58V03) 04.10.30A ve 04.10.30B birlikte kullanılacaktır. / 04.10.30A and 04.10.30B will be used together.</p>	
	<p>04.10.27 KANAT KAPAĞI CAP FOR VENT Malzeme / Material: PVC (ATS58V03-ATS58V04-ATS58V07-ATS58V13 için)</p>				

01











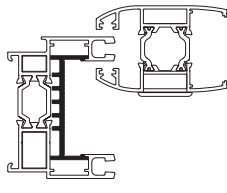

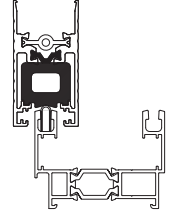
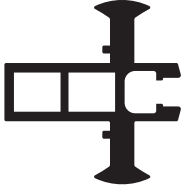
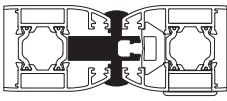

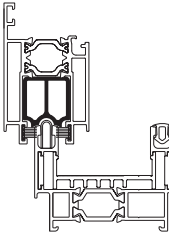
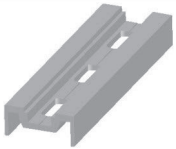
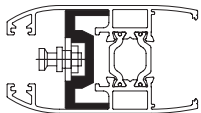

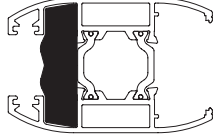
02

03

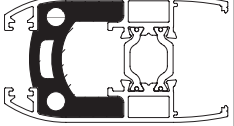
04

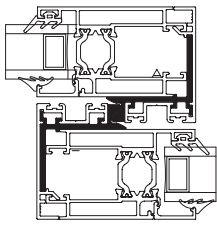
05

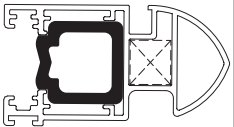
06

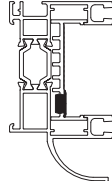
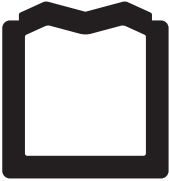
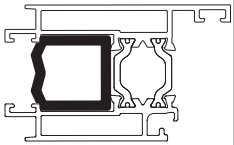
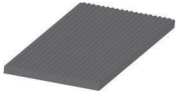
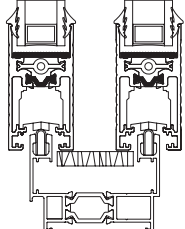
	 <p>02.03.15 PVC YALITIM ADAPTÖRÜ PVC ADAPTER FOR INSULATION Malzeme / Material: PVC Paket / Package: 6 mt</p> 	 <p>11.05.01 KANAT SABİTLEME TAKOZU WENT FIXING PART Malzeme / Material: PVC</p> 
01	 <p>02.03.16 ORTA BİRLESİM ADAPTÖRÜ ADAPTER FOR MIDDLE CONNECTION Malzeme / Material: PVC</p> 	 <p>11.05.05 KANAT SABİTLEME TAKOZU WENT FIXING PART Malzeme / Material: PVC (ATS58V13 için / for ATS58V13)</p> 
02	 <p>02.03.17 TİJLİ KİLİT ADAPTÖRÜ ROD LOCKING SYSTEM ADAPTER Malzeme / Material: PVC (120 mm)</p> 	 <p>19.01.04 STOPER STOPER Malzeme / Material: EPDM (ATS58V01 için / for ATS58V01)</p> 
03	 <p>02.03.18 SİNEKLİK ADAPTÖRÜ INSECT SCREEN ADAPTER Malzeme / Material: PVC</p> 	 <p>19.01.06 STOPER STOPER Malzeme / Material: EPDM (ATS58V02 için / for ATS58V02)</p> 
04	 <p>02.03.20 ORTA KENET ADAPTÖRÜ MIDDLE CLAMPING ADAPTER Malzeme / Material: PVC</p> 	 <p>19.01.10 STOPER STOPER Malzeme / Material: EPDM (ATS58V06 için / for ATS58V06)</p> 
05	 <p>04.19.01 PVC TAPA PVC PLUG Malzeme / Material: PVC</p> 	 <p>19.01.11 STOPER STOPER Malzeme / Material: EPDM (ATS58V13 için / for ATS58V13)</p> 
06	 <p>11.02.20 CAM TAKOZU GLASS SUPPORT Malzeme / Material: PVC</p> 	

 <p>07.05.28 RESCARA GLOBAL PENCERE KOLU (TEK DİLLİ) RESCARA GLOBAL HANDLE FOR WINDOWS (SINGLE RAIL) Renk / Colour: Siyah-Beyaz-Gri Black-White-Grey</p> <p>EN 1670</p>	 <p>07.05.25 GIESSE İSPANYOLEK KOL (ÇİFT DİLLİ) GIESSE HANDLE FOR WINDOWS (DOUBLE RAIL) Renk / Colour: Siyah-Beyaz-Gri Black-White-Grey</p> <p>UNI CEI EN ISO / IEC 17050</p>
 <p>07.05.32 RESCARA GLOBAL PENCERE KOLU (ÇİFT DİLLİ) RESCARA GLOBAL HANDLE FOR WINDOWS (DOUBLE RAIL) Renk / Colour: Siyah-Beyaz-Gri Black-White-Grey</p> <p>EN 1670, 13126-8</p>	 <p>07.25.01 GIESSE TİJ BAĞLANTI PARÇASI GIESSE CONNECTION ROD Renk / Colour: Siyah-Black Malzeme / Material: Polyamid / Polyamide</p> <p>07.05.25 Kol için / For Handle 07.05.25</p>
 <p>07.13.08 RESCARA KOL BAĞLANTI PARÇASI RESCARA CONNECTION PART FOR HANDLE Malzeme / Material: PVC</p> <p>07.05.32 Kol için / For Handle 07.05.32</p>	 <p>07.13.07 KOL BAĞLANTI PARÇASI CONNECTION PART FOR HANDLE Malzeme / Material: Zamak -Zamak</p> <p>07.05.28 Kol için / For Handle 07.05.28</p>
 <p>16.05.07 KİLİT ADAPTÖRÜ LOCK ADAPTER</p> <p>07.05.25, 07.05.28 ve 07.05.32 Kolları için / For Handles 07.05.25, 07.05.28 and 07.05.32</p>	 <p>16.05.02 SÜRME KİLİT KARŞILIĞI STRIKER FOR SLIDING LOCK</p> <p>07.05.25, 07.05.28 ve 07.05.32 Kolları için / For Handles 07.05.25, 07.05.28 and 07.05.32</p>
 <p>16.04.04 SÜRME DİL SLIDING BOLT</p> <p>07.05.25, 07.05.28 ve 07.05.32 Kolları için / For Handles 07.05.25, 07.05.28 and 07.05.32</p>	

01

02

03

04



05

06

KOL İLE KİLİTLEME SEÇİM TABLOSU
LOCKING KIT SELECTION TABLE WITH HANDLE

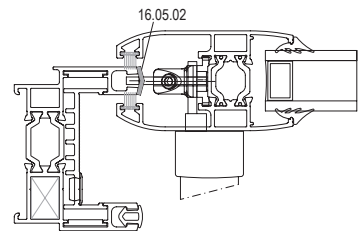
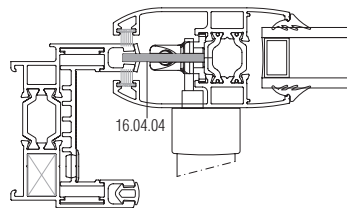
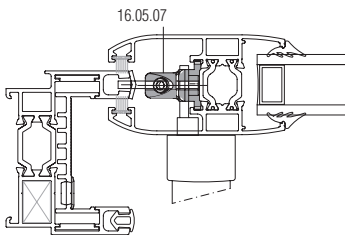
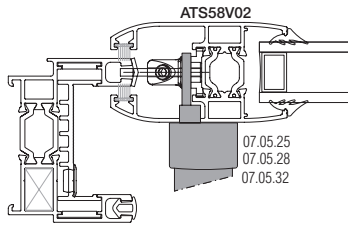
KOD CODE	TANIM DESCRIPTION	ADET NUMBER				KANAT VENT	
		H: 0-1200 mm	H: 1201-1799 mm	H: 1800-2199mm	H: 2200-2500 mm		
RESCARA TEK DİLLİ KOL RESCARA SINGLE RAIL HANDLE	07.05.28	RESCARA GLOBAL PENCERE KOLU RESCARA GLOBAL HANDLE	1	1	1	1	ATS58V02
	07.13.07	KOL BAĞLANTI PARÇASI CONNECTION PART FOR HANDLE	1	1	1	1	
GIESSE ÇİFT DİLLİ KOL GIESSE DOUBLE RAIL HANDLE	07.05.25	GIESSE İSPANYOLET KOL GIESSE HANDLE FOR WINDOWS	1	1	1	1	
	07.25.01	GIESSE TIJ BAĞLANTI PARÇASI GIESSE CONNECTION ROD	1	1	1	1	
RESCARA ÇİFT DİLLİ KOL RESCARA DOUBLE RAIL HANDLE	07.05.32	RESCARA PENCERE KOLU RESCARA GLOBAL HANDLE	1	1	1	1	
	07.13.08	RESCARA KOL BAĞLANTI PARÇASI RESCARA CONNECTION ROD	1	1	1	1	
16.05.07	KİLİT ADAPTÖRÜ LOCK ADAPTÖR	2	3	4	5		
16.04.04	SÜRME DİL SLIDING BOLT	2	3	4	5		
16.05.02	SÜRME KİLİT KARŞILIĞI STRIKER FOR SLIDING LOCK	2	3	4	5		

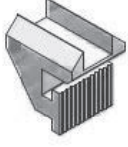
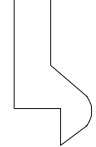

 <p>07.10.12 HAVUZLU KİLİT ANAHTARLI SLIDING LOCK WITH KEY Malzeme / Material: Alüminyum- Zamak Aluminium -Zamak</p>	 <p>07.10.13 HAVUZLU KİLİT SLIDING LOCK Malzeme / Material: Alüminyum- Zamak Aluminium -Zamak</p>
 <p>07.10.14 ÇİFTLİ HAVUZLU KİLİT ANAHTARLI DOUBLE SLIDING LOCK WITH KEY Malzeme / Material: Alüminyum- Zamak Aluminium -Zamak</p>	 <p>07.10.09 HAVUZ KOL SLIDING HANDLE Malzeme / Material: Alüminyum- Zamak Aluminium -Zamak</p>
 <p>07.11.03 KOL ÜSTÜ KARŞILIK STRIKER FOR HANDLE 07.10.12 , 07.10.13 , 07.10.14 Sürme Kilit için / For Handles 07.10.12 , 07.10.13 , 07.10.14</p>	 <p>16.05.05 SÜRME KİLİT ADAPTÖRÜ LOCK ADAPTER 07.10.12 , 07.10.13 , 07.10.14 Sürme Kilit için / For Handles 07.10.12 , 07.10.13 , 07.10.14</p>

01

02

03

04

05

06

HAVUZLU KOL İLE KİLİTLEME SEÇİM TABLOSU

LOCKING KIT SELECTION TABLE WITH HANDLE

KOD CODE	TANIM DESCRIPTION	ADET NUMBER	KANAT VENT
07.10.12 07.10.13 07.10.14	HAVUZLU KİLİT SLIDING LOCK	1	ATS58V01 ATS58V02 ATS58V13
16.05.06	SÜRME KİLİT KARŞILIĞI STRIKER FOR SLIDING LOCK	1	
07.11.03	KOL ÜSTÜ KARŞILIK STRIKER FOR HANDLE	1	

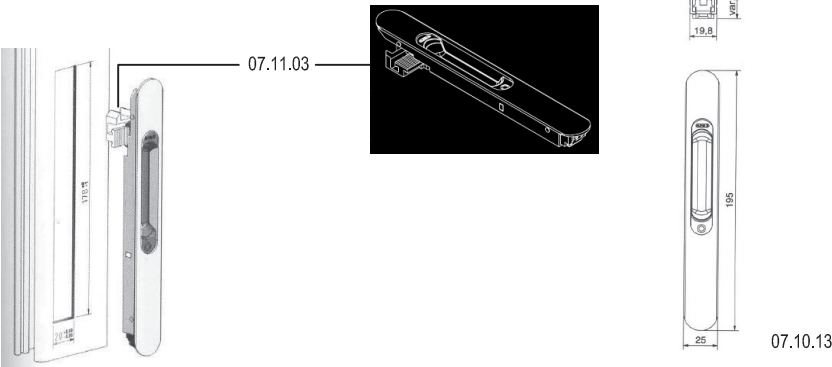
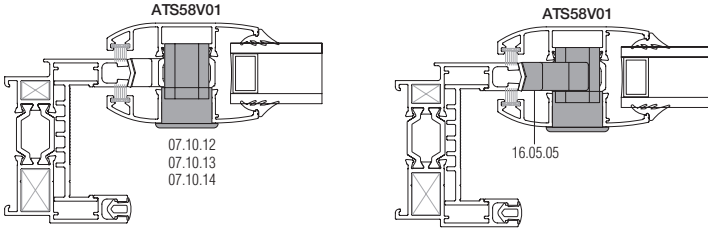



07.05.41

RESCARA AKUSTİK PENCERE KOLU
RESCARA ACOUSTIC HANDLE

Renk / Colour: Siyah-Beyaz-Gri
Black-White-Grey



07.05.42

RESCARA AKUSTİK PENCERE KOLU
RESCARA ACOUSTIC HANDLE

Renk / Colour: Siyah-Beyaz-Gri
Black-White-Grey



07.05.48

RESCARA GİZLİ SÜRME KOLU
RESCARA HIDDEN SLIDING HANDLE

Renk / Colour: Siyah-Beyaz-Gri
Black-White-Grey

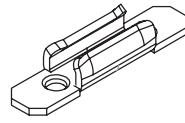

16.05.08

SÜRME KİLİT KARŞILIĞI
STRIKER FOR SLIDING LOCK

07.05.41, 07.05.42, 07.05.48 PVC Kol için / For PVC Handle 07.05.41, 07.05.42, 07.05.48

07.18.XX

22 EKSEN SÜRME İSPANYOLETİ İ
22 AXIS STEEL GEARBOX SLIDING ESPOGNOLETTE

Renk / Colour: Siyah-Beyaz-Gri
Black-White-Grey



04.20.01

KARŞILIK ALT PLASTİK PARÇASI
TIN PLATE STRIKER FOR SLIDING LOCK

07.18.xx 22 EKSEN SÜRME İSPANYOLETİ
07.18.xx 22 AXIS STEEL GEARBOX SLIDING ESPOGNOLETTE

KOD CODE	ÖLÇÜ DIMENSION
07.18.24	h: 600mm-800 mm / 22
07.18.25	h: 800mm-1000mm / 22
07.18.26	h: 1000mm-1200mm / 22
07.18.27	h: 1200mm-1400mm / 22
07.18.28	h: 1400mm-1600mm / 22
07.18.29	h: 1600mm-1800mm / 22
07.18.30	h: 1800mm-2000mm / 22
07.18.31	h: 2000mm-2100mm / 22

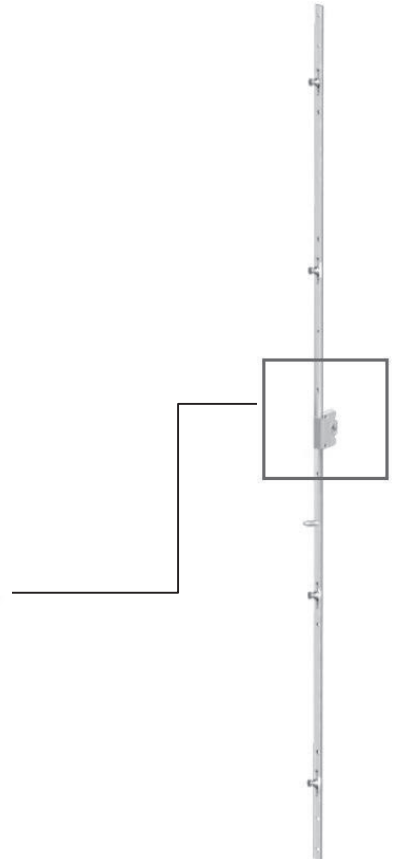
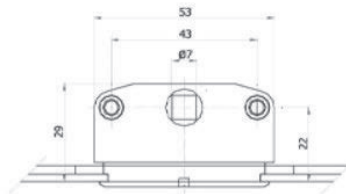

01

02

03

04

05

06

PVC KOL İLE KİLİTLEME SEÇİM TABLOSU

LOCKING KIT SELECTION TABLE WITH PVC HANDLE

KOD CODE	TANIM DESCRIPTION	ADET NUMBER	KANAT VENT
07.05.41 07.05.42 07.05.48	PVC İSPANYOLET KOL PVC HANDLE	1	ATS58V02
16.05.08	SÜRME KİLİT KARŞILIĞI STRIKER FOR SLIDING LOCK	BKZ.07.18.xx SEÇİM TABLOSU SEE 07.18.xx SELECTION TABLE	
04.20.01	SÜRME SAC KARŞILIĞI TIN PLATE STRIKER FOR SLIDING LOCK	BKZ. 07.18.xx SEÇİM TABLOSU SEE 07.18.xx SELECTION TABLE	
07.18.XX	SÜRME İSPANYOLETİ SLIDING ESPOGNOLETTE	1	

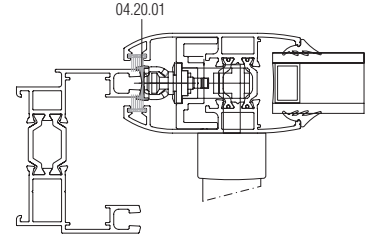
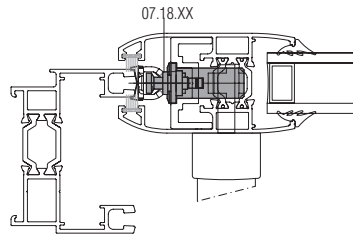
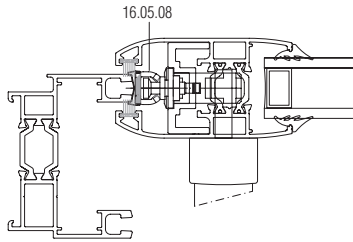
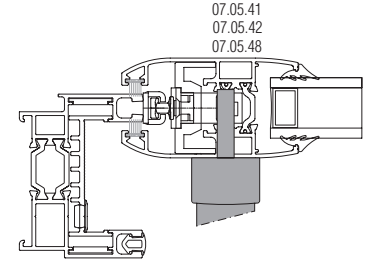

07.18.xx 22 EKSEN SÜRME İSPANYOLETİ
07.18.xx 22 AXIS STEEL GEARBOX SLIDING ESPOGNOLETTE

KOD CODE	TANIM DESCRIPTION	16.05.08 ADET/NUMBER	04.20.01 ADET/NUMBER
07.18.24	h: 600mm-800mm / 22	2	2
07.18.25	h:800mm-1000mm / 22	2	2
07.18.26	h: 1000mm-1200mm / 22	3	3
07.18.27	h: 1200mm-1400mm / 22	3	3
07.18.28	h: 1400mm-1600mm / 22	3	3
07.18.29	h:1600mm-1800mm / 22	3	3
07.18.30	h:1800mm-2000mm / 22	4	4
07.18.31	h: 2000mm-2200mm / 22	4	4

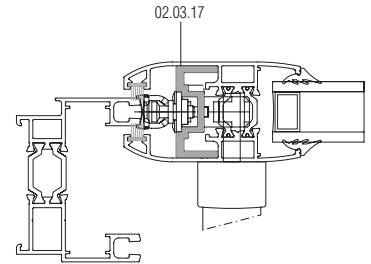



16.02.02

GIESSE AYARLI ÇİFTLİ RULMAN
GESSE ADJUSTABLE CARRERA 2 PULLEYS

Malzeme / Material: Alüminyum- Zamak
Aluminium -Zamak

2 Adet 180 kg taşır. / 180 kg with 2 pulleys
EN 13126-15 : 2008

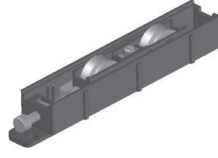

16.02.07

RESCARA AYARLI ÇİFTLİ RULMAN
RESCARA ADJUSTABLE CARRERA 2 PULLEYS

2 Adet 120 kg taşır. / 120 kg with 2 pulleys

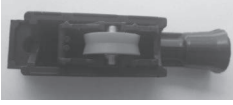

16.01.01

AYARLI TEKLİ RULMAN
PULLEY WITH SINGLE WHEEL

Malzeme / Material: Alüminyum- Zamak
Aluminium -Zamak

2 Adet 35 kg taşır. / 35 kg with 2 pulleys
Max. kanat ölçüsü 600x1500./ Max. vent dimension 600x1500

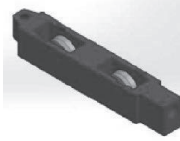

16.01.02

AYARLI ÇİFTLİ RULMAN
ADJUSTABLE PULLEY

Malzeme / Material: Alüminyum- Zamak
Aluminium -Zamak

2 Adet 65 kg taşır. / 65 kg with 2 pulleys
Max. kanat ölçüsü 1000x2100./ Max. vent dimension 1000x2100

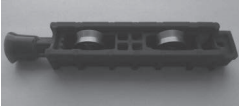

16.01.12

METAL TEKERLEKLİ AYARLI RULMAN
STEEL ADJUSTABLE PULLEYS

2 Adet 65 kg taşır. / 65 kg with 2 pulleys
Max. kanat ölçüsü 1000x2100./ Max. vent dimension 1000x2100



16.01.13

METAL TEKERLEKLİ AYARLI RULMAN
PULLEY WITH SINGLE WHEEL

2 Adet 35 kg taşır. / 35 kg with 2 pulleys
Max. kanat ölçüsü 600x1500./ Max. vent dimension 600x1500



16.02.06

SİNEKLİK RULMANI
PULLEY FOR INSECT SCREEN

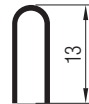

16.06.02

ÇELİK RAY
STEEL RAIL

Malzeme / Material: Paslanmaz Çelik
Stainless Steel

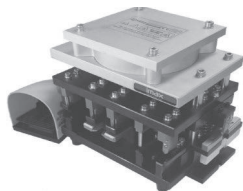

21.01.07

PUNCH MAKİNESİ
PUNCH MACHINE

Pnömatik

01

02

03

04

05

06

MİMARİ KATALOG
ARCHITECTURAL CATALOGUE

Alüminyum Kapı Pencere ve Giydirme Cephe Sistemleri
Aluminium Door Window and Facade Systems

RST58

İMALAT DETAYLARI

FABRICATION DETAILS

(1) KASA KÖŞE BAĞLANTI DETAYI
FRAME CORNER DETAIL

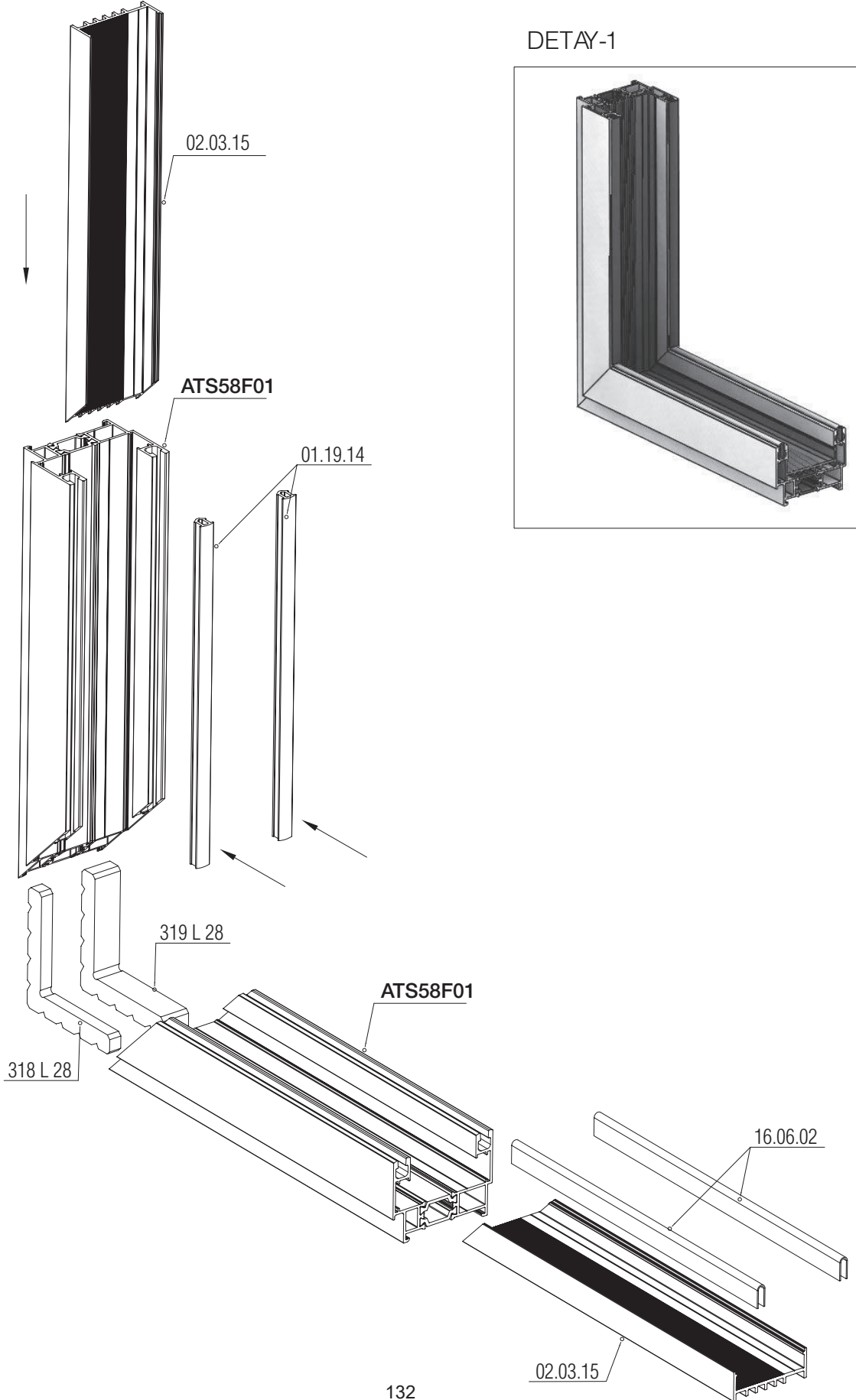

01

02

03

04

05

06

(2) DÜŞEY - YATAY KANAT BAĞLANTI DETAYI (ÜST)
VERTICAL & HORIZONTAL VENT CONNECTION DETAIL (UPPER)

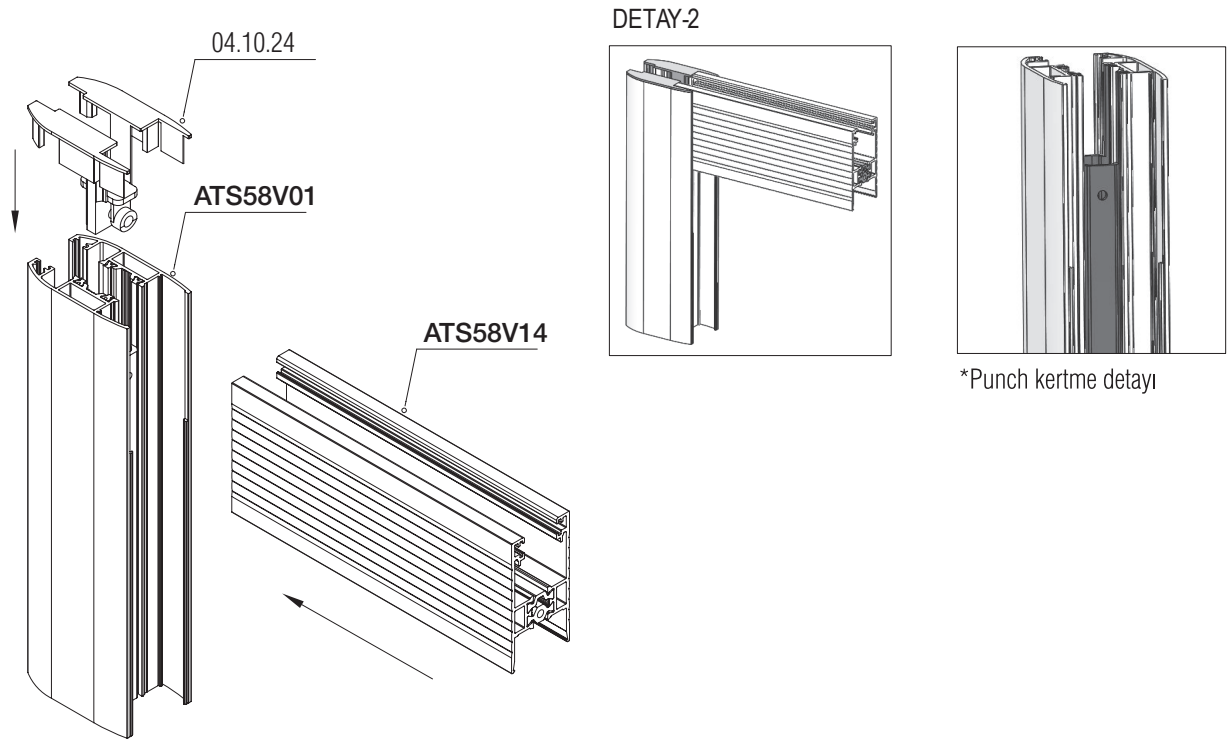

(3) DÜŞEY - YATAY KANAT BAĞLANTI DETAYI (ALT)
VERTICAL & HORIZONTAL VENT CONNECTION DETAIL (BOTTOM)

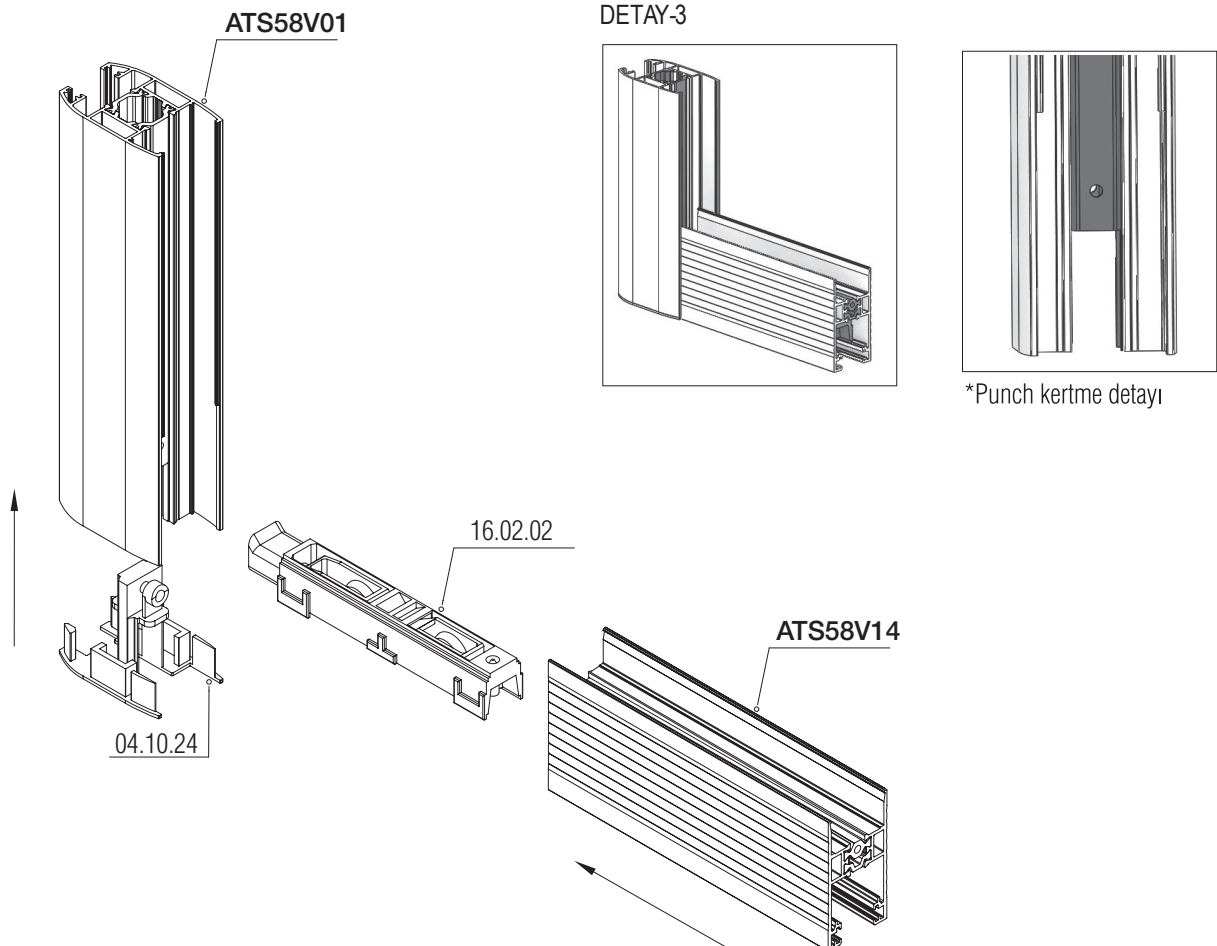

01

02

03

04

05

06

(4) DÜŞEY - YATAY KANAT BAĞLANTI DETAYI (ÜST)
VERTICAL & HORIZONTAL VENT CONNECTION DETAIL (UPPER)

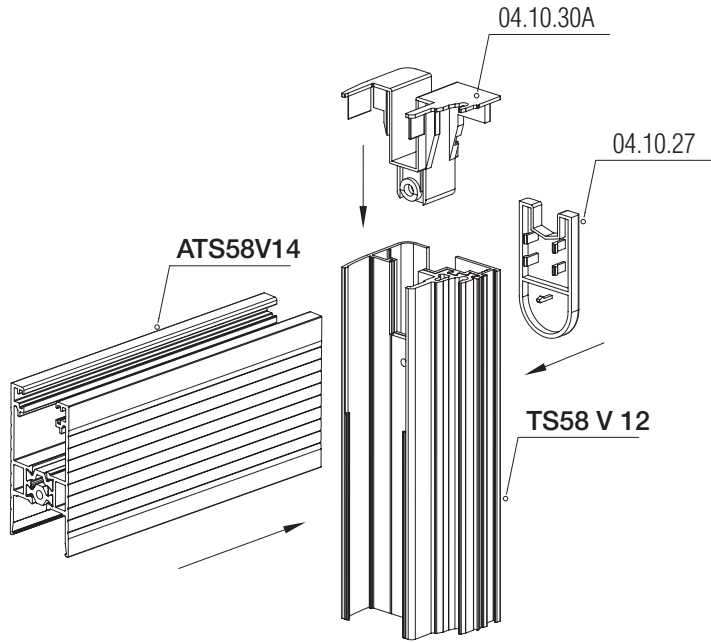

DETAY-4

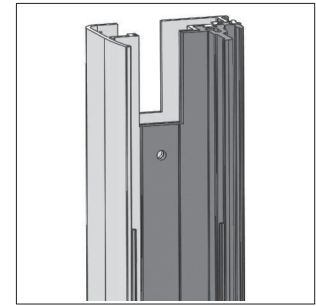
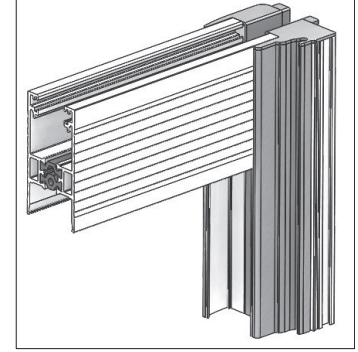

*Punch kertme detayı

(5) DÜŞEY - YATAY KANAT BAĞLANTI DETAYI (ALT)
VERTICAL & HORIZONTAL VENT CONNECTION DETAIL (BOTTOM)

DETAY-5

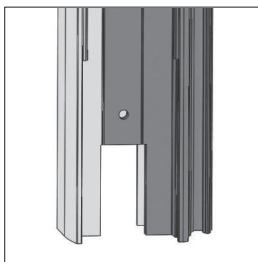
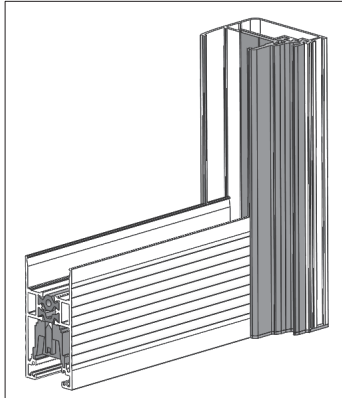

*Punch kertme detayı

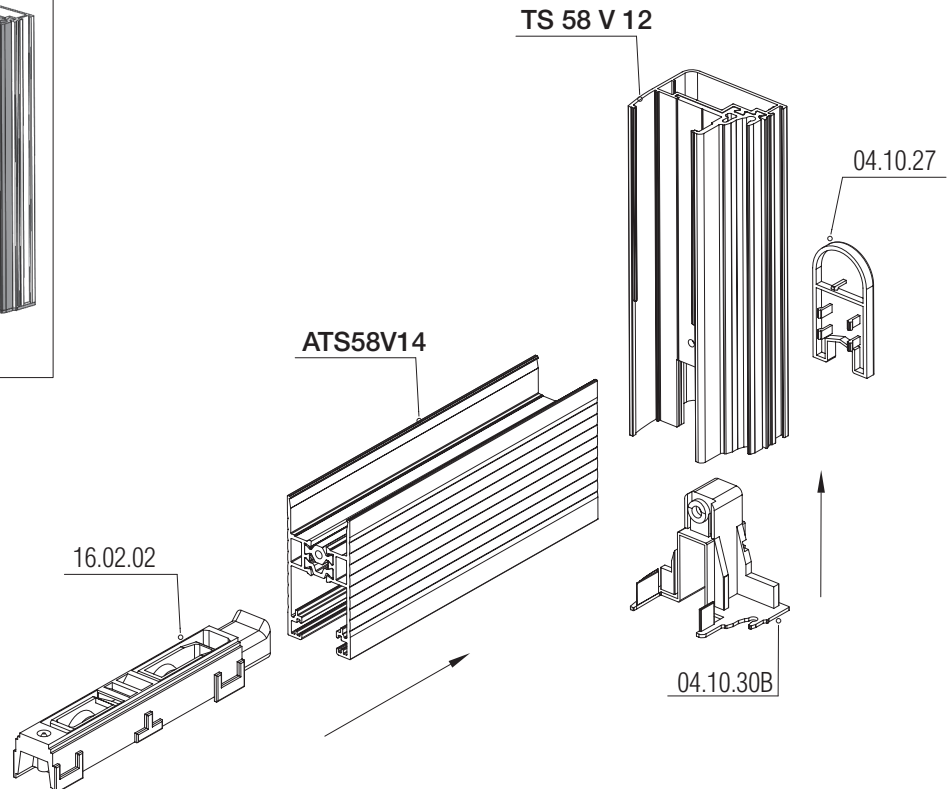

(6) KENET BAĞLANTI DETAYI (ÜST)
CONNECTION DETAIL (UPPER)

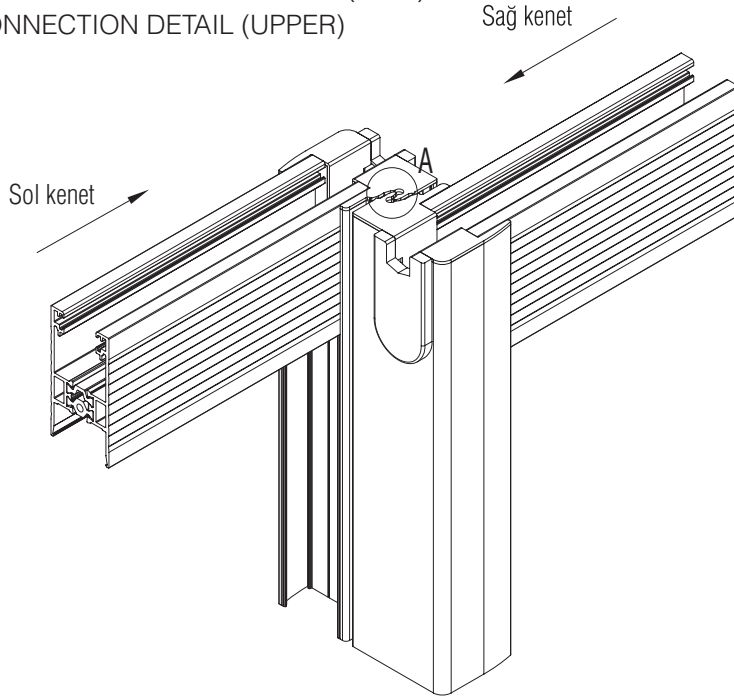

DETAY-6

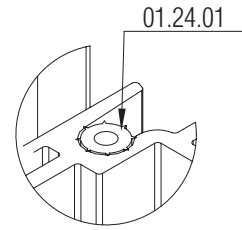
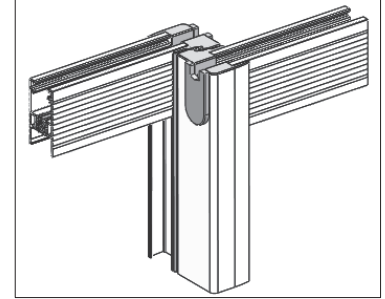

Detay/Detail-A
Ölçek/Scale 2:1

(7) KENET BAĞLANTI DETAYI (ALT)
CONNECTION DETAIL (BOTTOM)

DETAY-7

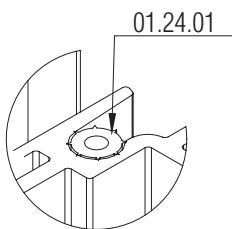
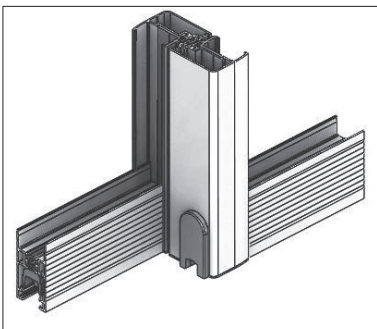

Detay/Detail-B
Ölçek/Scale 2:1

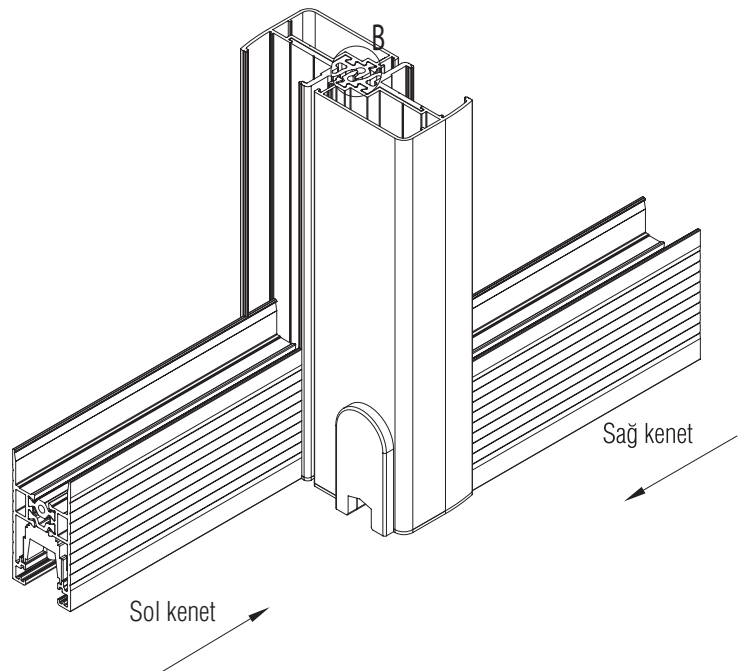

01

02

03

04

05

06

