

Tonellidesign

The New Modernism
2021 Collection

Tonellidesign

The New Modernism

Collection 2021

New Modernism nasce da una profonda, coraggiosa riflessione sull'abitare contemporaneo, dall'analisi del modo di abitare e da un pensiero che si lega al progetto di interior design nella sua accezione d'oggi.

La vocazione storica di Tonelli per la lavorazione del vetro, si apre a nuove interpretazioni, sorprendenti ed inaspettate, in affinità ad un modo di vivere la casa che riteniamo allineato ai tempi.

Un importante lavoro di ricerca verso nuove forme e funzioni, legate tra loro attraverso l'uso delle materie e delle relazioni che si creano, in un universo di nuovi significati.

La collezione 2021 si allarga alla casa nel suo insieme, un'interpretazione basata sul vetro, che risulta calda, accogliente, eclettica. Arredi diversi, in cui legni, metalli, pietre e pelli, abbinati al vetro suggeriscono un modello di casa originale e personale. Funzionalità e rigore, decorazione e presenze scultoree, sono la proposta di Tonelli ad un cliente alla ricerca di una casa unica e senza tempo, lontana da stili formali e stereotipati.

Collection 2021

New Modernism was born of a deep, brave reflection on contemporary living, of an analysis of the way of living and of a thought linked to the project of interior design in its nowadays meaning.

Tonelli's historical vocation for glass manufacturing opens to new interpretations, surprising and unexpected, in kinship with a way of living the home we consider aligned with the present times.

An important research for new forms and functions, linked between them by using the materials and the relationships thus created, in a universe of new meanings.

Collection 2021 opens up to the home in its wholeness, an interpretation based on glass that results warm, welcoming, eclectic. Different furnishings where wood, metal, stones and leathers, combined with the glass, suggest an original and personal model of home. Functionality and rigor, decoration and sculptural presences, are Tonelli's proposals for a customer looking for a unique and timeless home, distant from formal and stereotypical styles.

Index Collection

Major sideboard	7
Marcell console / desk / dressing table	21
Whirl mirror	33
Crossover dining table	41
Perseo dining table	55
Hyperion lamp	65
Maybe mirror	75
She chair	81

Major
sideboard

design
Bellavista & Piccini

Un mobile contenitore caratterizzato dalla struttura in vetro e dai frontali in essenza. Major offre composizioni pensate per i diversi usi e le diverse aree della casa, personalizzabili e variabili in base agli stili e ai gusti.

Sideboard featuring a glass structure and frontal parts in wood. Major offers compositions thought for different uses and different home areas, adaptable and changeable according to personal style and taste.

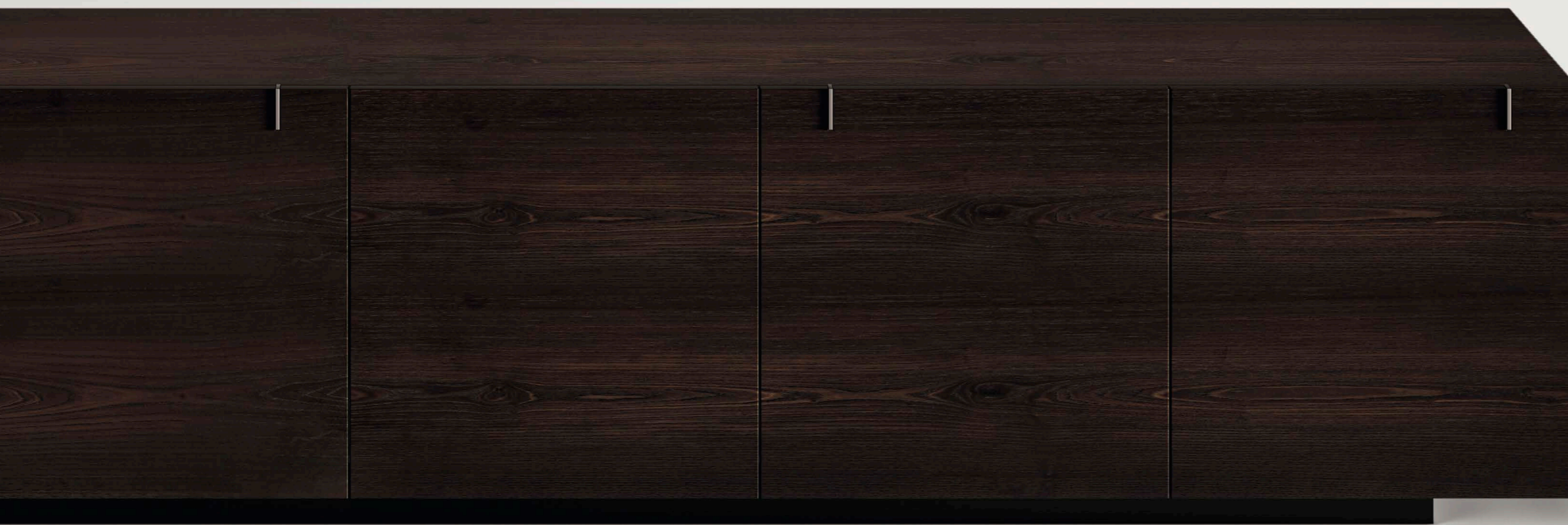



Le ante sono dotate di una sottile maniglia che, oltre a rappresentare un elegante dettaglio di design, integra il sistema magnetico di apertura e blocco.

The doors are equipped with a slim handle, an elegant design detail that completes the magnetic system of opening and halting.

La madia Major offre un sistema di apertura delle ante unico e innovativo. La combinazione di ante scorrevoli e battenti, permette alla madia di apparire sempre diversa e di essere utilizzata secondo le proprie esigenze.

Sideboard Major offers a unique and innovative door opening system. The combination of sliding and hinge doors allows the sideboard to always show different aspects and to be used according to one's necessities.







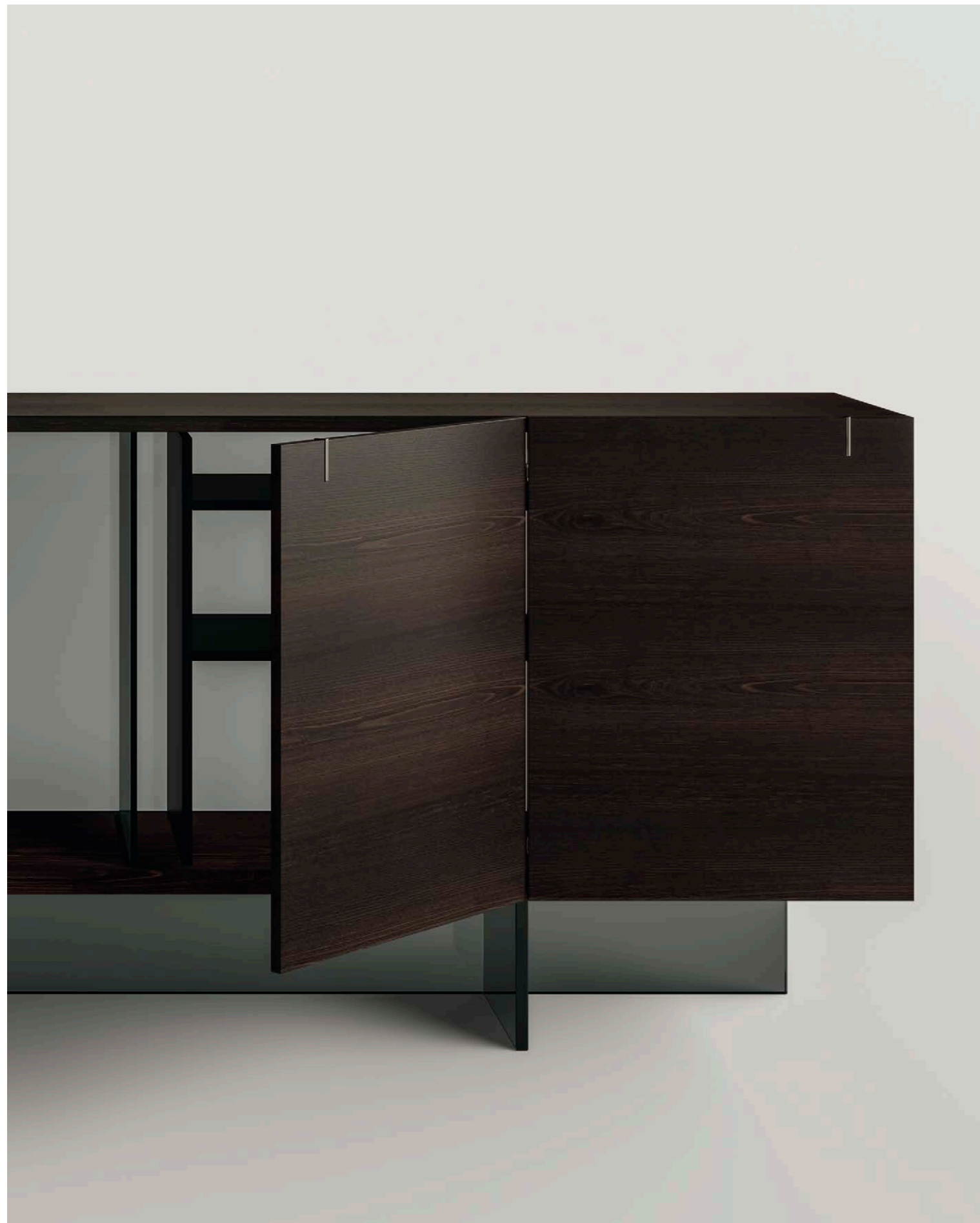

Major sideboard

INFO TECNICHE / TECHNICAL INFO

Madia composta da top, fondo e ante in legno a vena continua nelle finiture Eucalipto o Siberian Ash. Struttura verticale composta da fianchi, schiena e fianchi interni in vetro nelle versioni fumè o bronzo. Basamento in vetro extra chiaro spessore 19 mm oppure vetro fumè o bronzo stratificato spessore 10+10 mm. In alternativa, zoccolo in legno verniciato nero opaco con regolazione integrata. L'interno può essere personalizzato con comodi elementi divisori in legno laccato nero.

Sideboard made of top, bottom and doors in wood with continuous vein in Eucalipto and Siberian Ash finish. Vertical structure made of sides, back and internal partition in glass in smoked or bronze finish. Base in extra clear glass 19mm thick or stratified bronze or smoked glass 10+10mm. In alternative it can be with black lacquered wooden plinth with integrated regulation. The inside can be personalized with dividing elements in black lacquered wood.

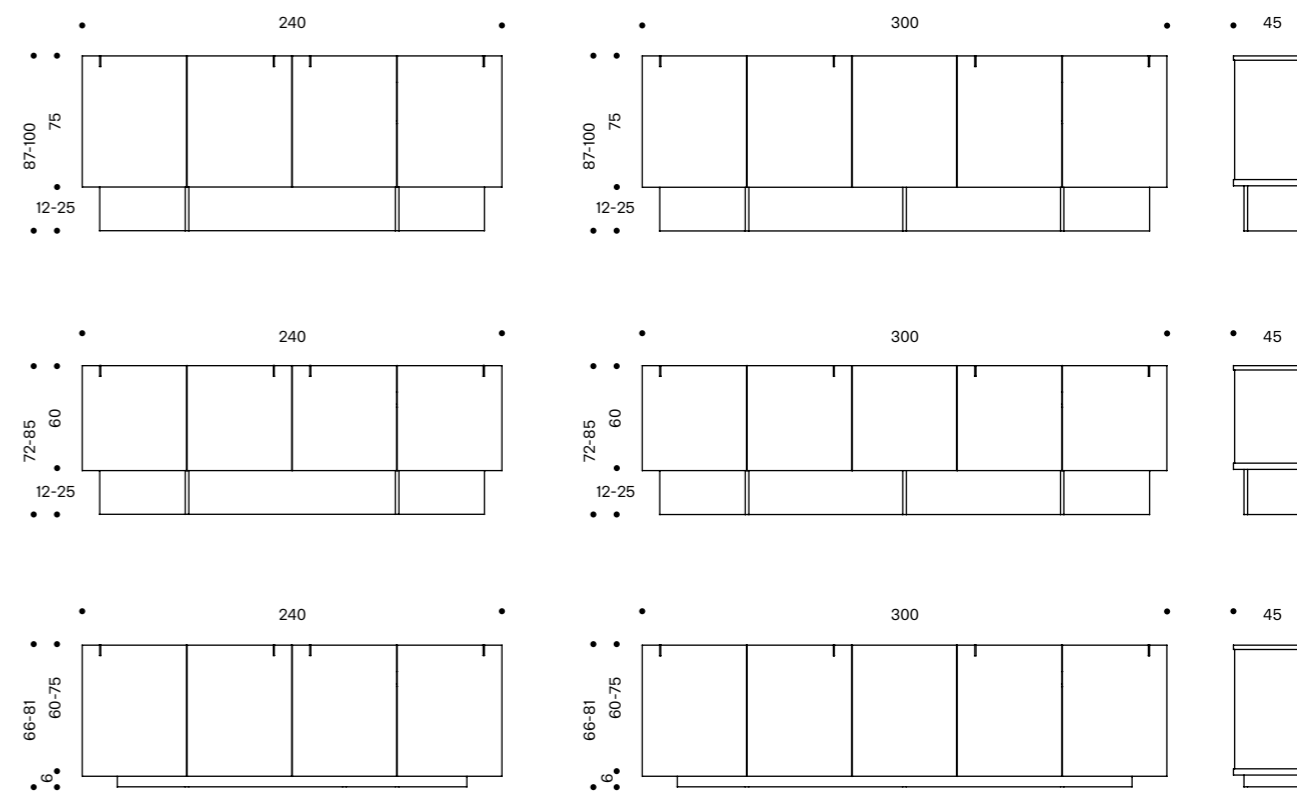

Marcell
console / desk
dressing table

design
Massimo Castagna

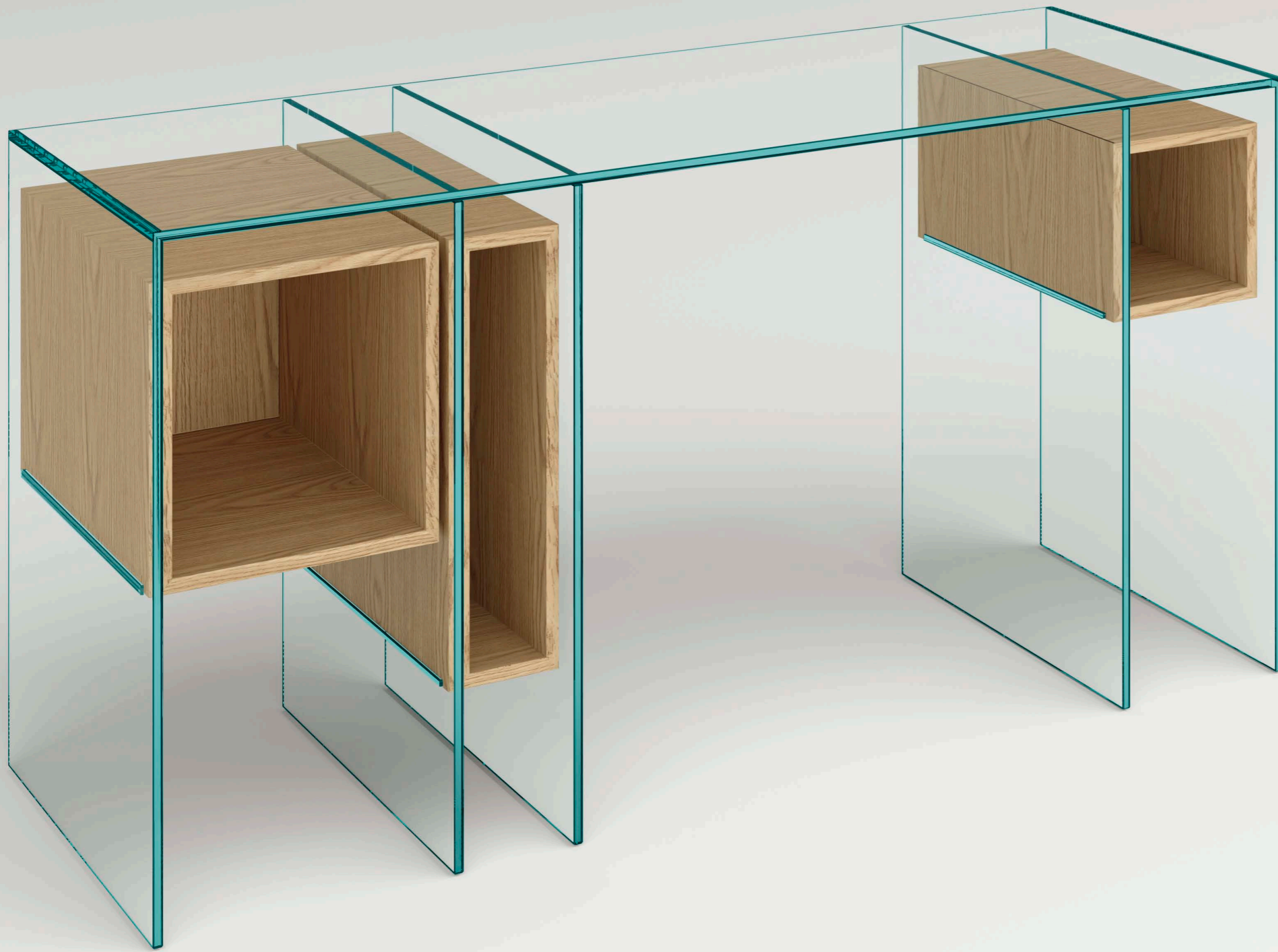

Marcell rappresenta un classico senza tempo, definito dalle linee essenziali e rigorose del vetro e dal calore e matericità del legno.

Marcell represents a timeless classic, defined by the essential and rigorous lines of the glass and the warmth and texture of the wood.

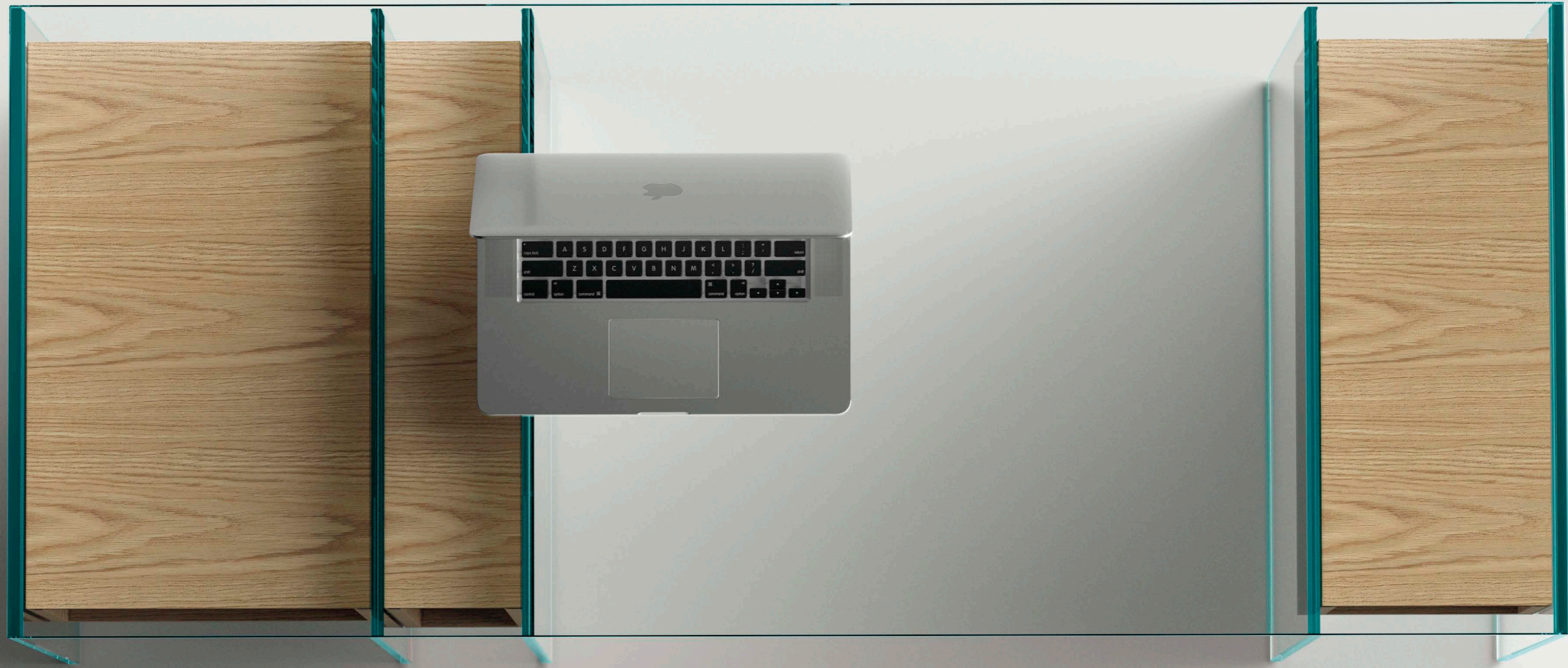

Grande versatilità d'uso nei diversi ambienti, Marcell nasce come scrittoio ma trova collocazione anche come console nell'ingresso e, se attrezzato con cassetti portaoggetti e specchio da appoggio, come dressing table diventando protagonista nella zona notte.

Great versatility for its use in different areas, Marcell is born as a desk but finds its place also as an entry console and, if equipped with glove box drawers and countertop mirror, as a dressing table, thus becoming the protagonist of the night area.

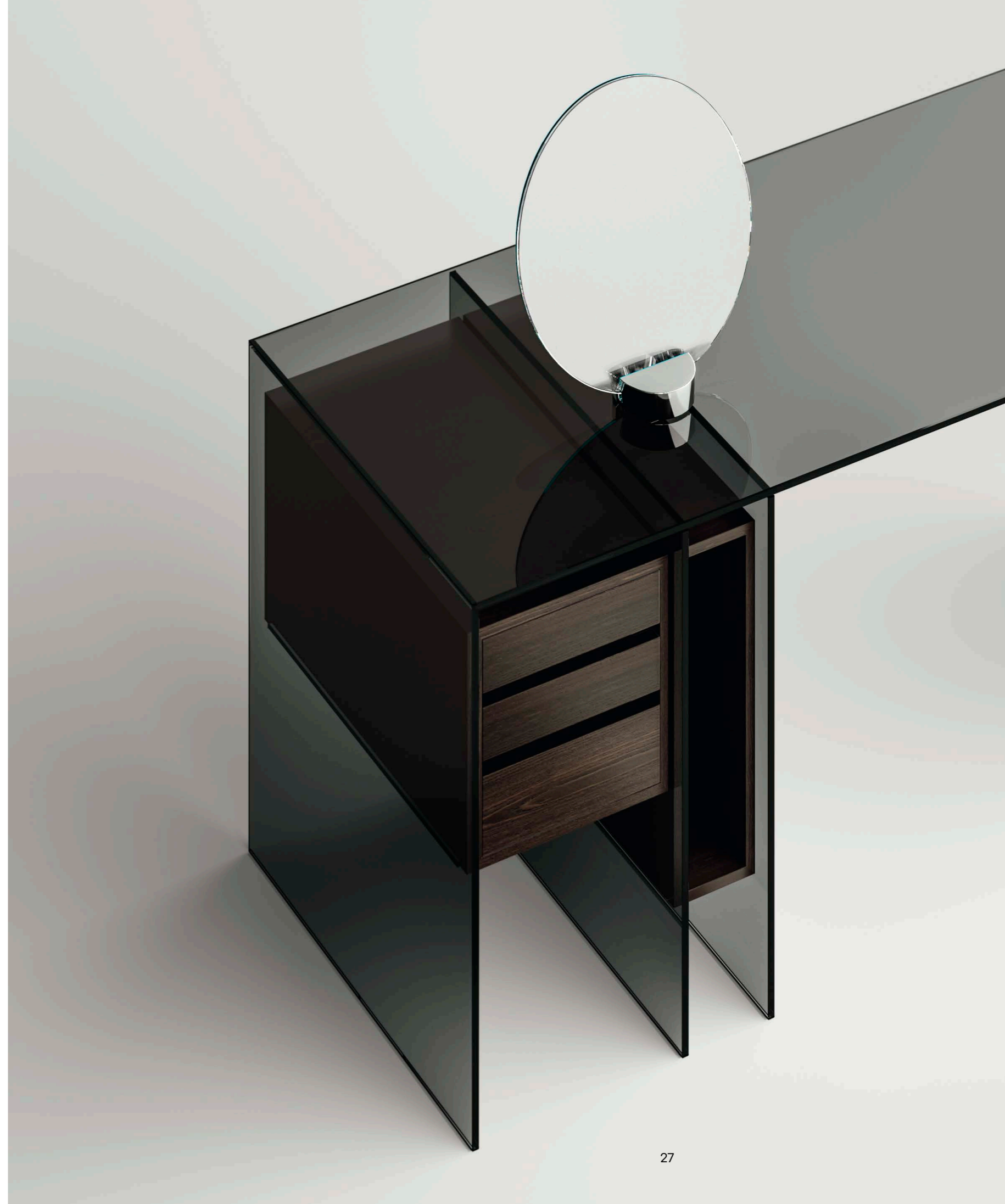

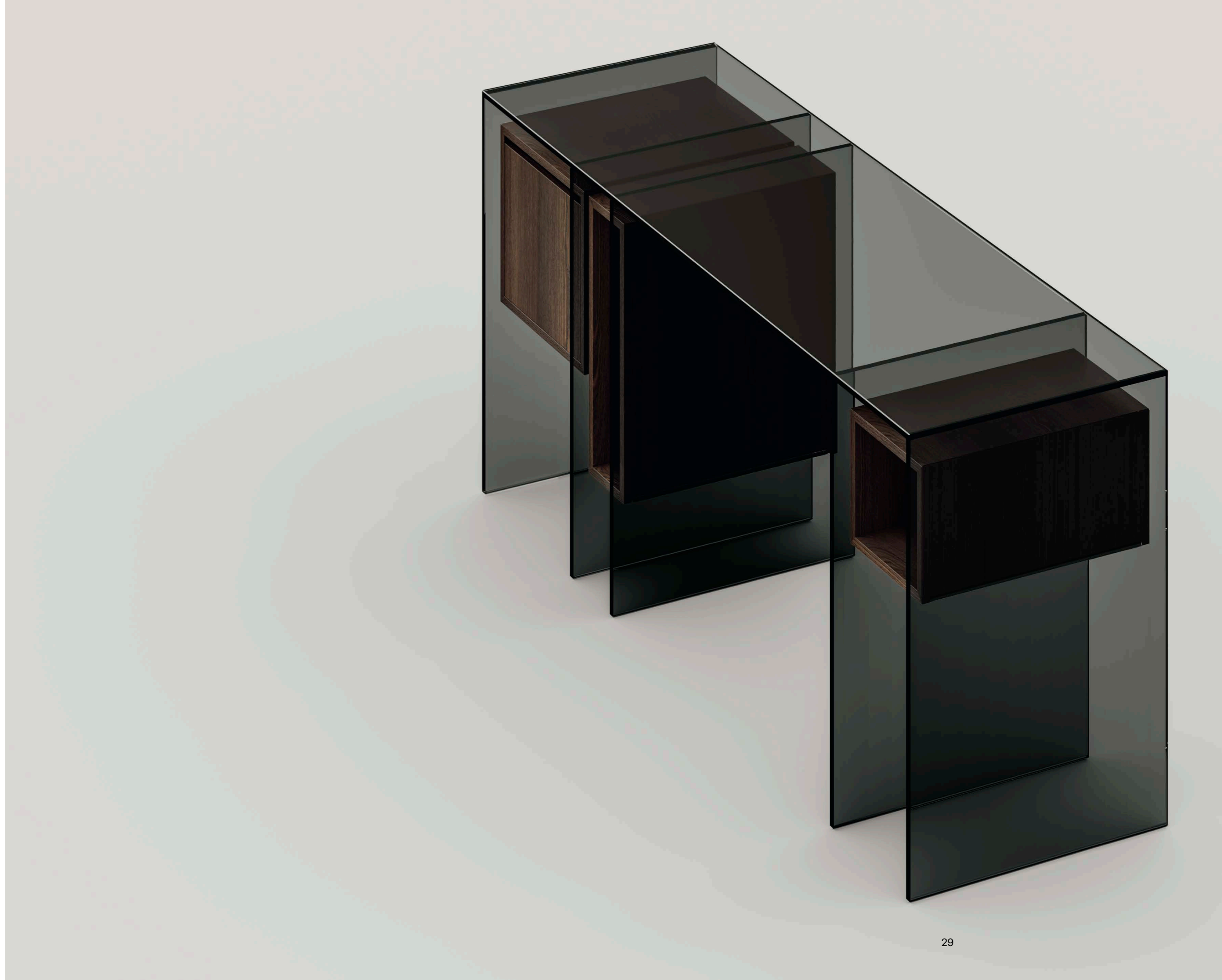



Marcell console / desk dressing table

INFO TECNICHE / TECHNICAL INFO

Console, scrittoio o dressing table con struttura incollata in vetro extra chiaro o fumè e contenitori in legno in finitura Eucalipto, Siberian Ash o Rovere Naturale. Sono optional l'anta battente SX o il set 3 cassetti in finitura abbinata. Lo scrittoio può essere completato con lo specchio in appoggio della stessa collezione con base in metallo cromato lucido.

Console, desk or dressing table with structure in glued glass extra clear or smoked and wooden storage units in Eucalipto, Siberian Ash or Natural Oak. Optional hinge door left or set of 3 drawers in matching finish. The desk can be completed with the countertop mirror of the same collection with polished chrome metal base.

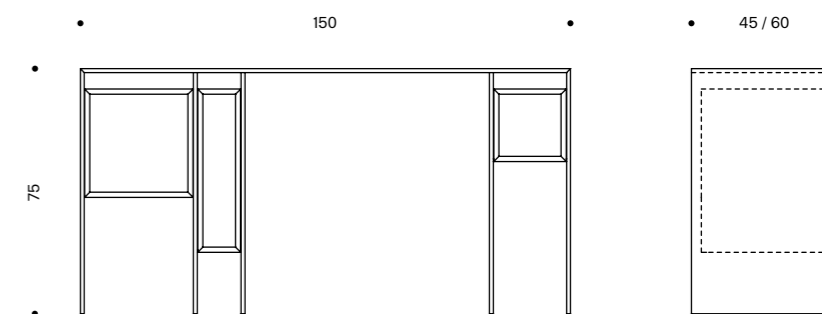

Whirl
mirror

design
Francesco Forcellini



Whirl è la rappresentazione grafica minima del vortice. L'inclinazione dei quattro specchi esterni crea un gioco prospettico che rende dinamica ed energica l'immagine rispecchiata sullo specchio centrale.

Whirl is the minimum graphic representation of a vortex. The inclination of the 4 outer mirrors creates a prospective play that energizes and gives a dynamical view of the image reflected in the central mirror.





Whirl mirror

INFO TECNICHE / TECHNICAL INFO

Specchio da parete con struttura in legno verniciata nero. E' disponibile in specchio, specchio fumè, bronzo e oro.

Wall mirror with black lacquered wooden structure. Available in mirror, smoked, bronze or gold mirror.

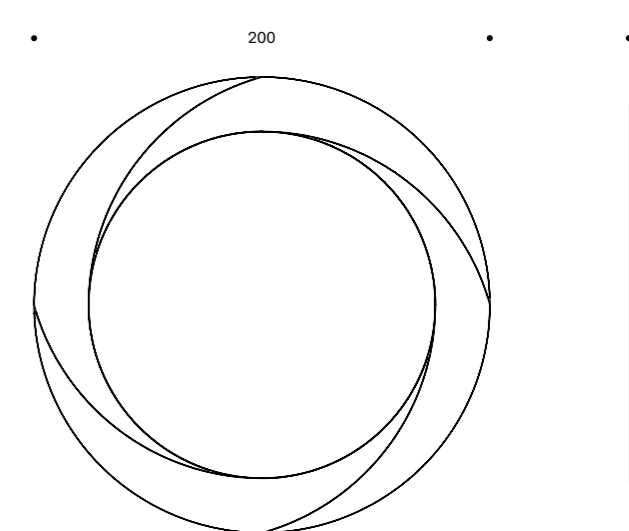

Crossover
dining table

design
Massimo Castagna

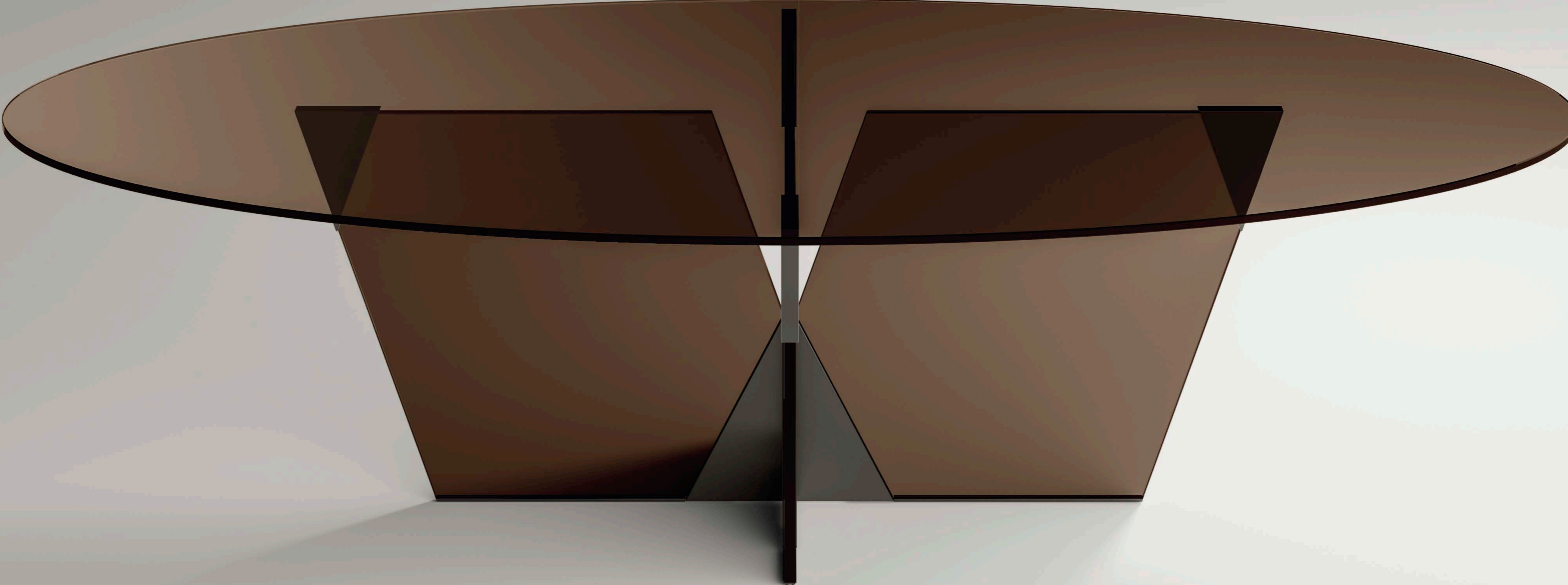

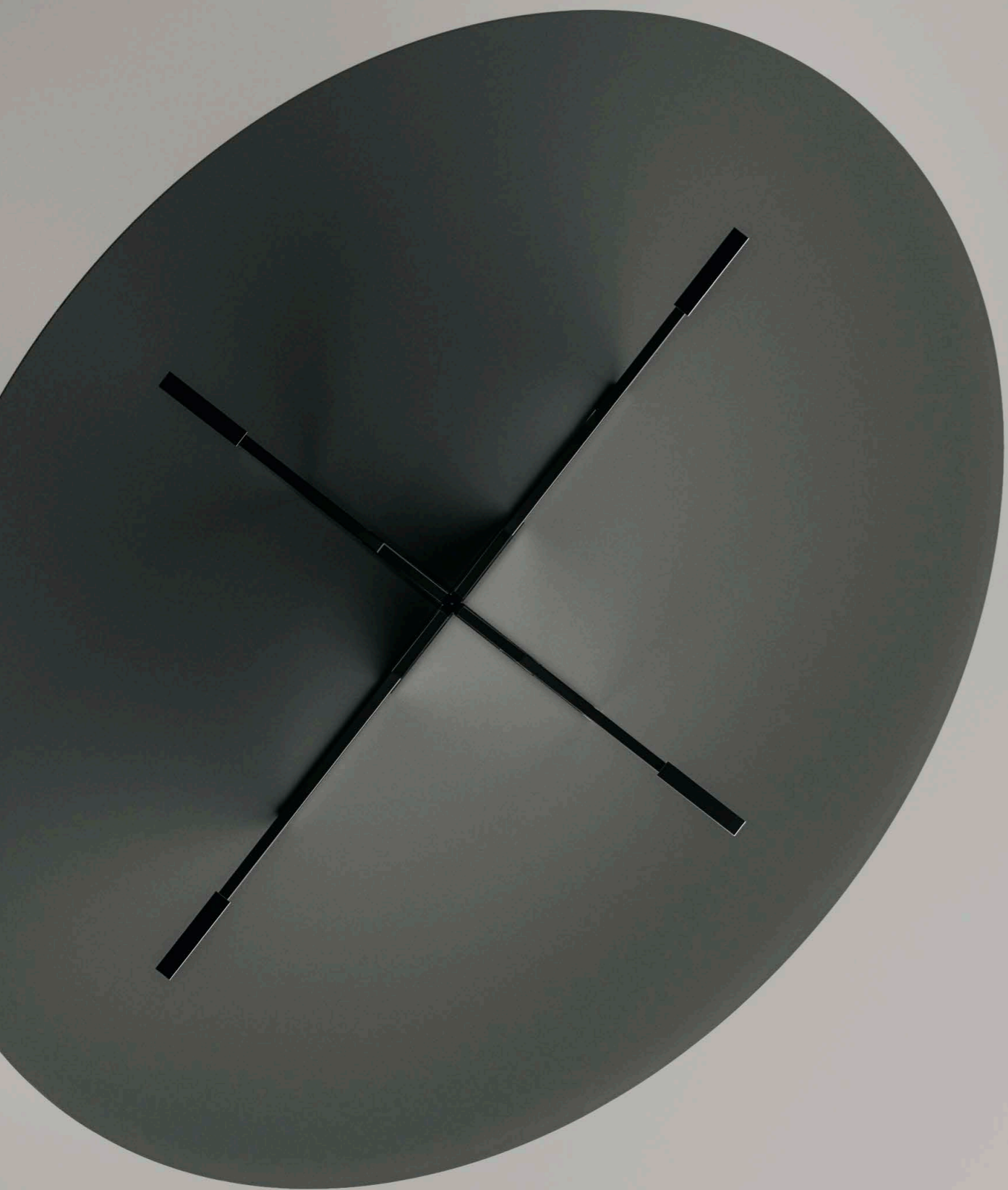

Una struttura scultorea ed elegante per il nuovo tavolo disegnato da Massimo Castagna. Capacità nel combinare materiali di diversa natura insieme alla straordinaria passione per la lavorazione del vetro permettono di modellare le forme e gli spessori fino a definire un'immagine di forza e di carattere.

A sculptural and elegant structure for the new table designed by Massimo Castagna. The ability to combine materials of different nature together with the extraordinary passion for glass processing allow to shape forms and thicknesses up until an image of great force and character is defined.

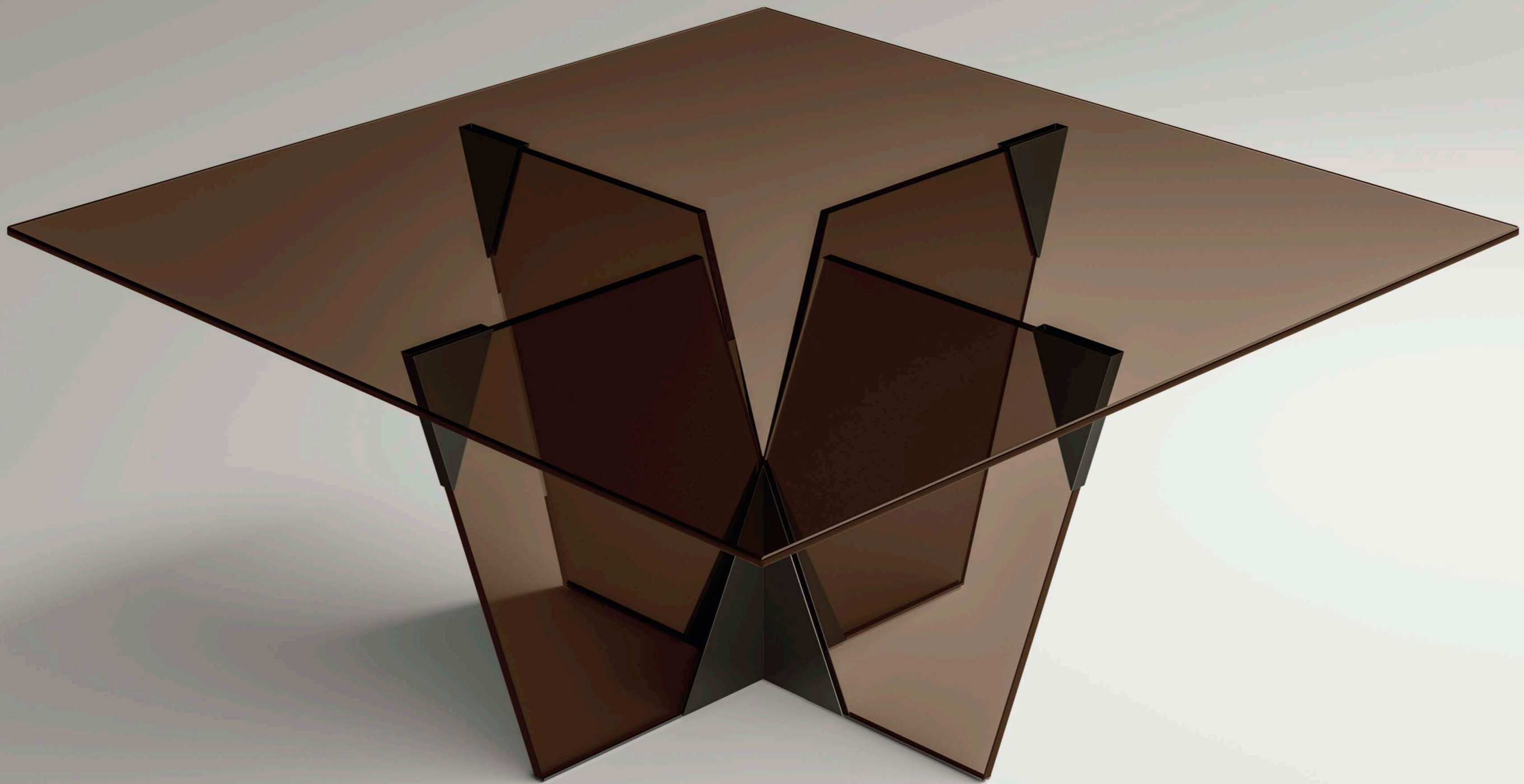

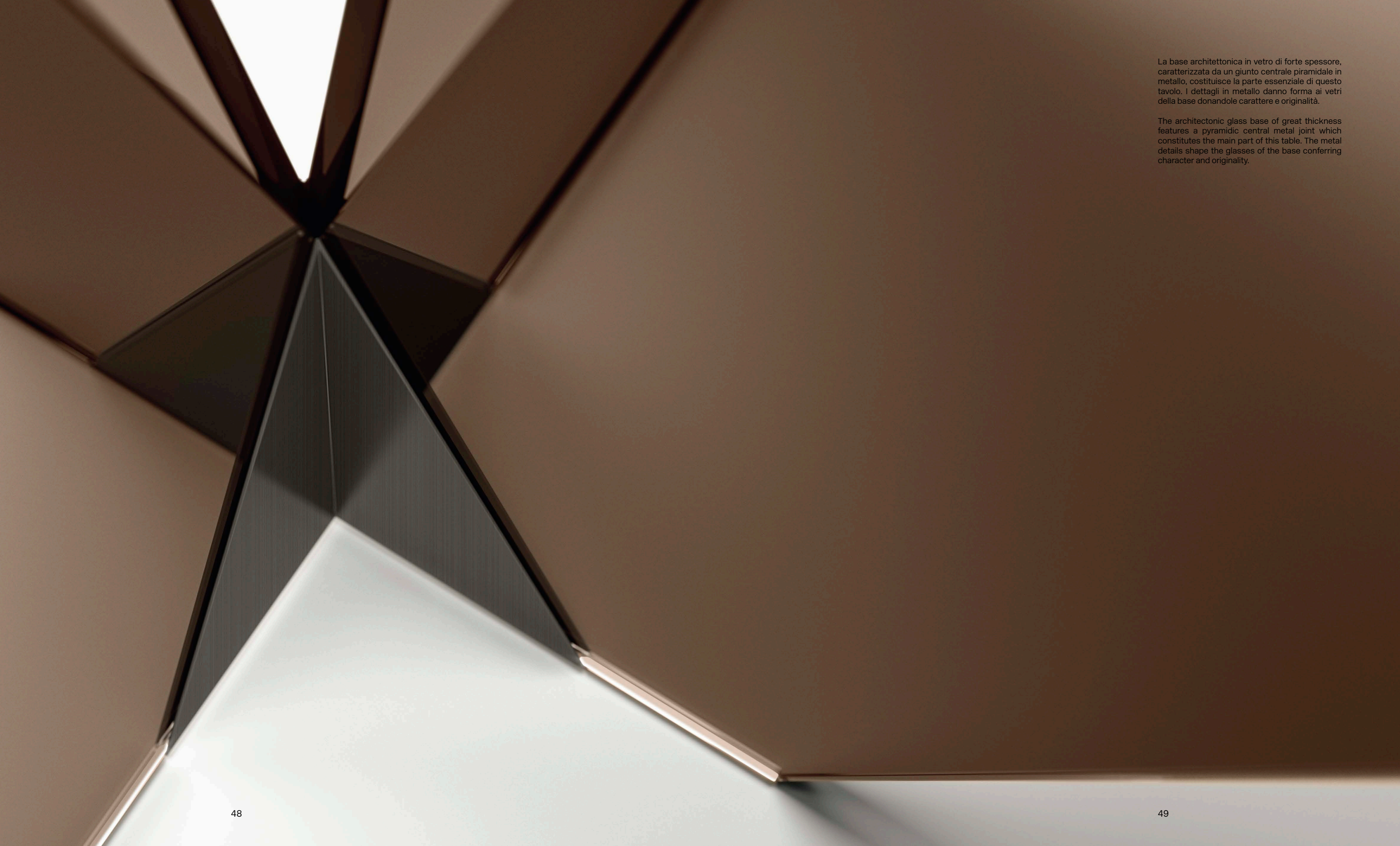

La base architettonica in vetro di forte spessore, caratterizzata da un giunto centrale piramidale in metallo, costituisce la parte essenziale di questo tavolo. I dettagli in metallo danno forma ai vetri della base donandole carattere e originalità.

The architectonic glass base of great thickness features a pyramidal central metal joint which constitutes the main part of this table. The metal details shape the glasses of the base conferring character and originality.

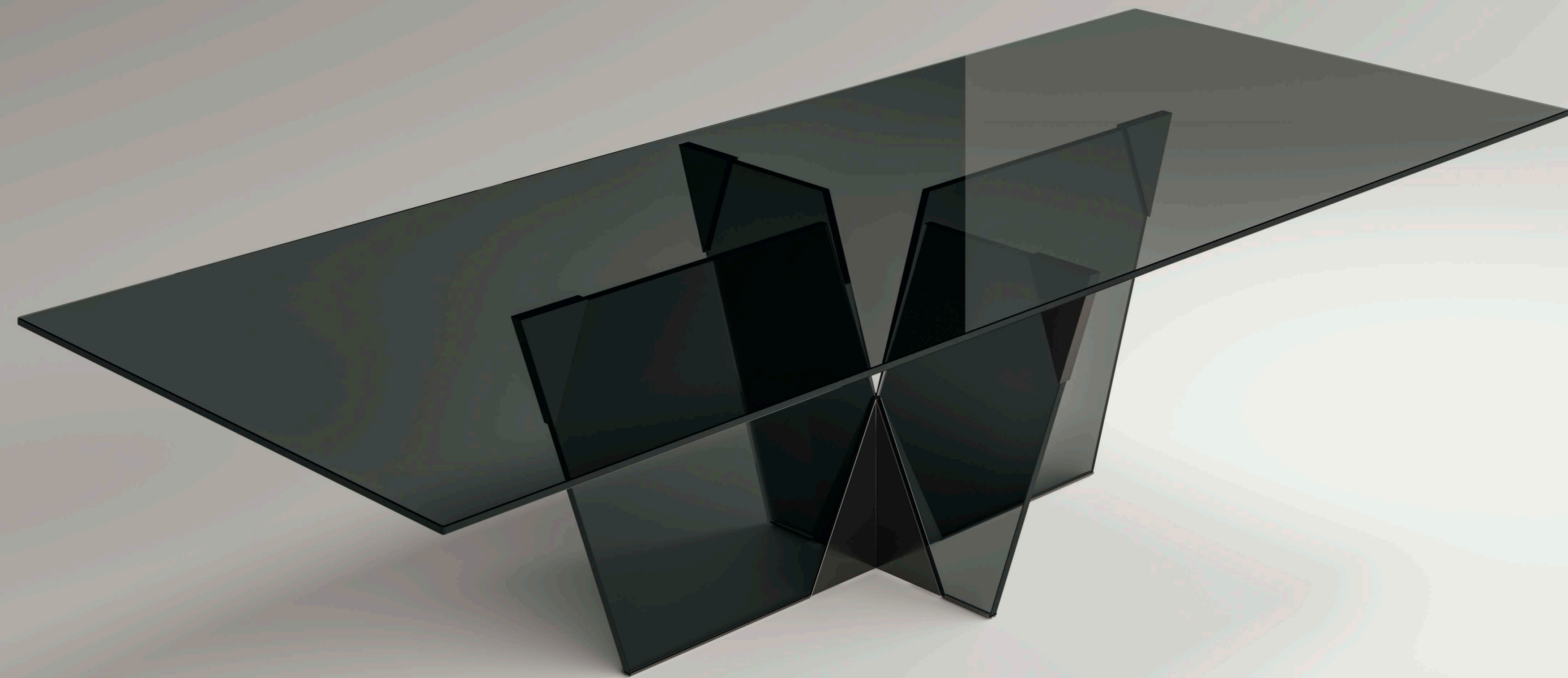



Crossover dining table

INFO TECNICHE / TECHNICAL INFO

Tavolo con basamento centrale in vetro extra chiaro, fumè o bronzo stratificato in spessore 10+10mm. Giunto centrale e supporti del piano in metallo finitura canna di fucile lucido o Titanio spazzolato opaco. La base è completamente smontabile e il piano è in appoggio con piastre metalliche per il centraggio. Piano in vetro extra chiaro temperato spessore 15mm oppure in vetro fumè o bronzo stratificato in spessore 10+6mm.

Table with base in extra clear, smoked or bronze stratified glass 10+10mm. Central joint and top supports in metal in polished gunmetal or matt brushed Titanium finish. The base is completely demountable and the table top rests on the base with metal plates for the centring. Table top in extra clear tempered glass of 15mm or in stratified smoked or bronze glass in 10+6mm.

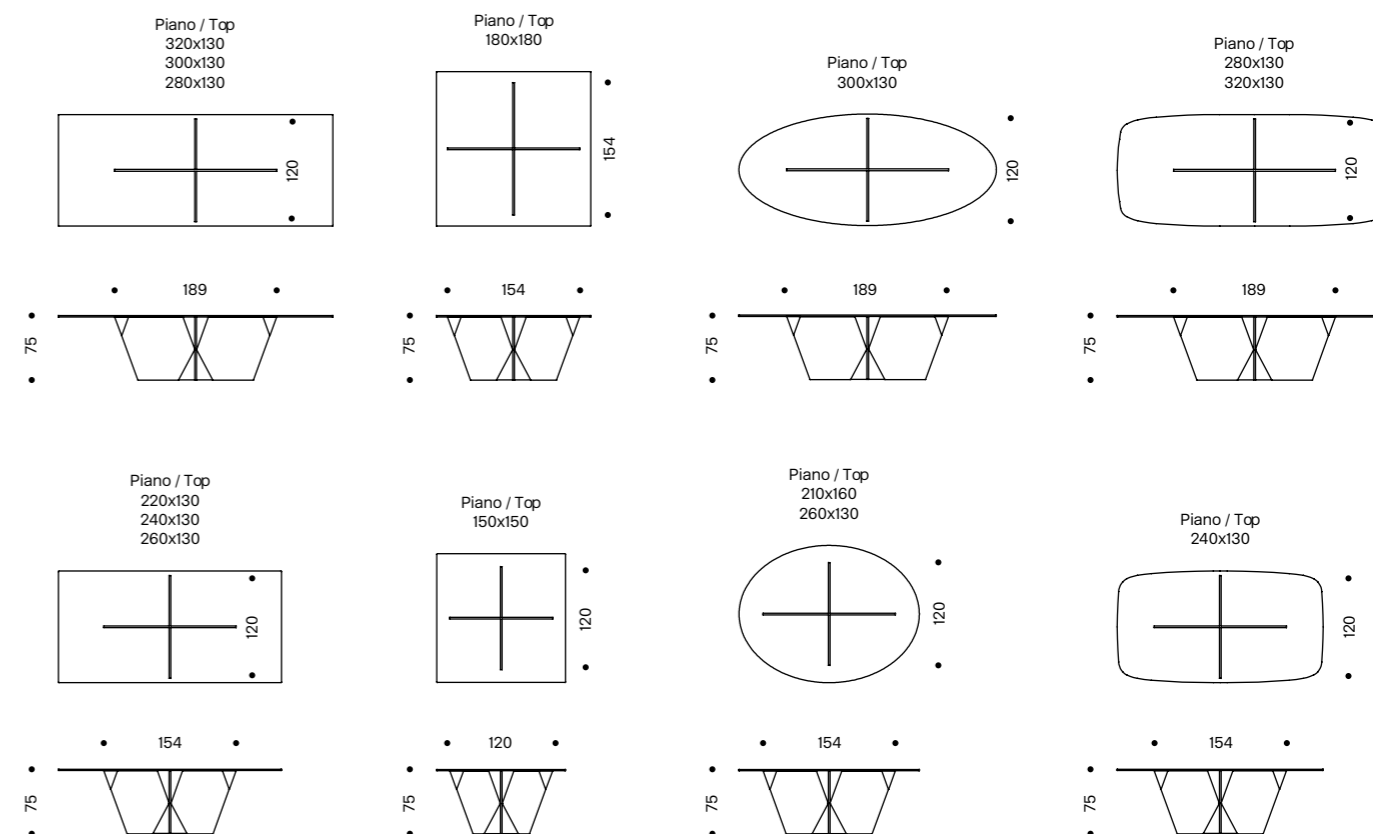

Perseo
dining table

design
Paolo Grasselli

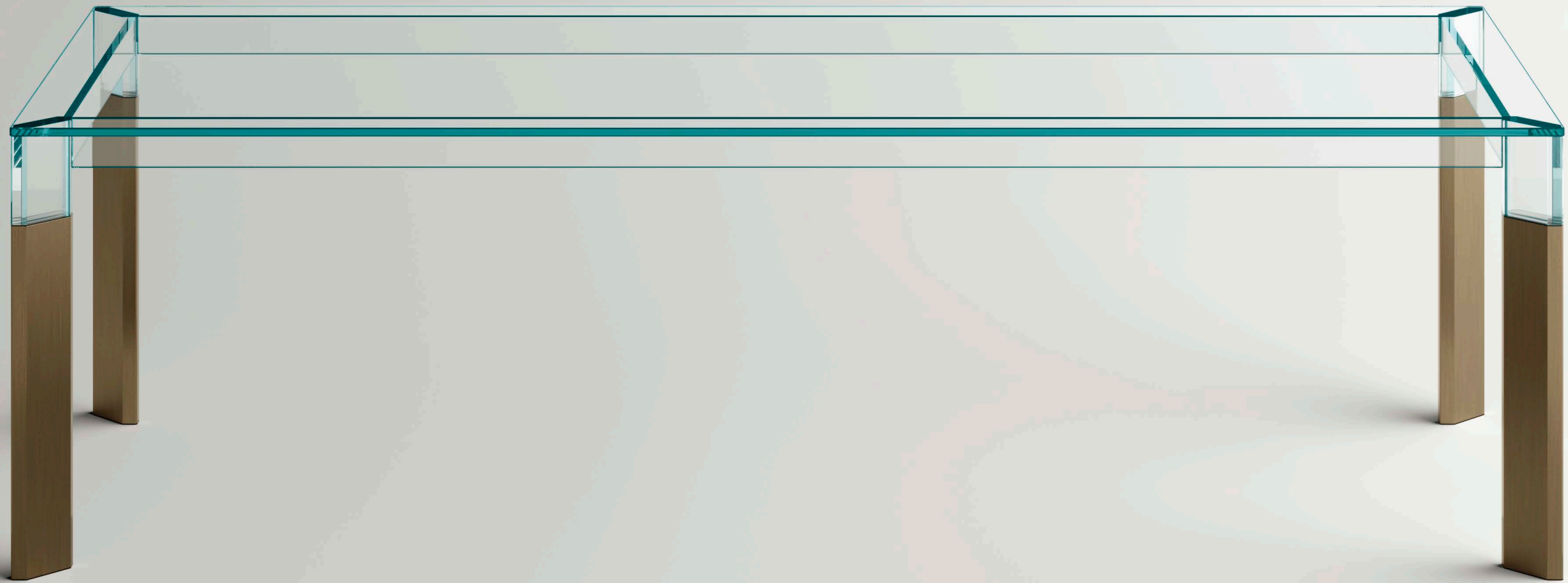



Grande protagonista tra i nostri tavoli, Perseo ha sempre saputo valorizzare l'unione del vetro ad altri materiali favorendone la versatilità abitativa all'interno degli spazi. Nella sua eleganza si legono tecniche costruttive complesse realizzate grazie alle abilità dei nostri artigiani.

Great protagonist among our tables, Perseo always knew how to enhance the combination of glass and other materials, thus gaining in versatility in its use. Complex construction techniques, obtained by the ability of our artisans, are to be seen in its elegance.

Oltre alle finiture già disponibili si aggiungono quelle nuove spazzolate opache per le gambe che rendono Perseo un tavolo senza tempo e adatto a stili diversi.

Beyond the already available finishes, two new brushed finishes for the legs are added that make Perseo a timeless table, adaptable to different styles.

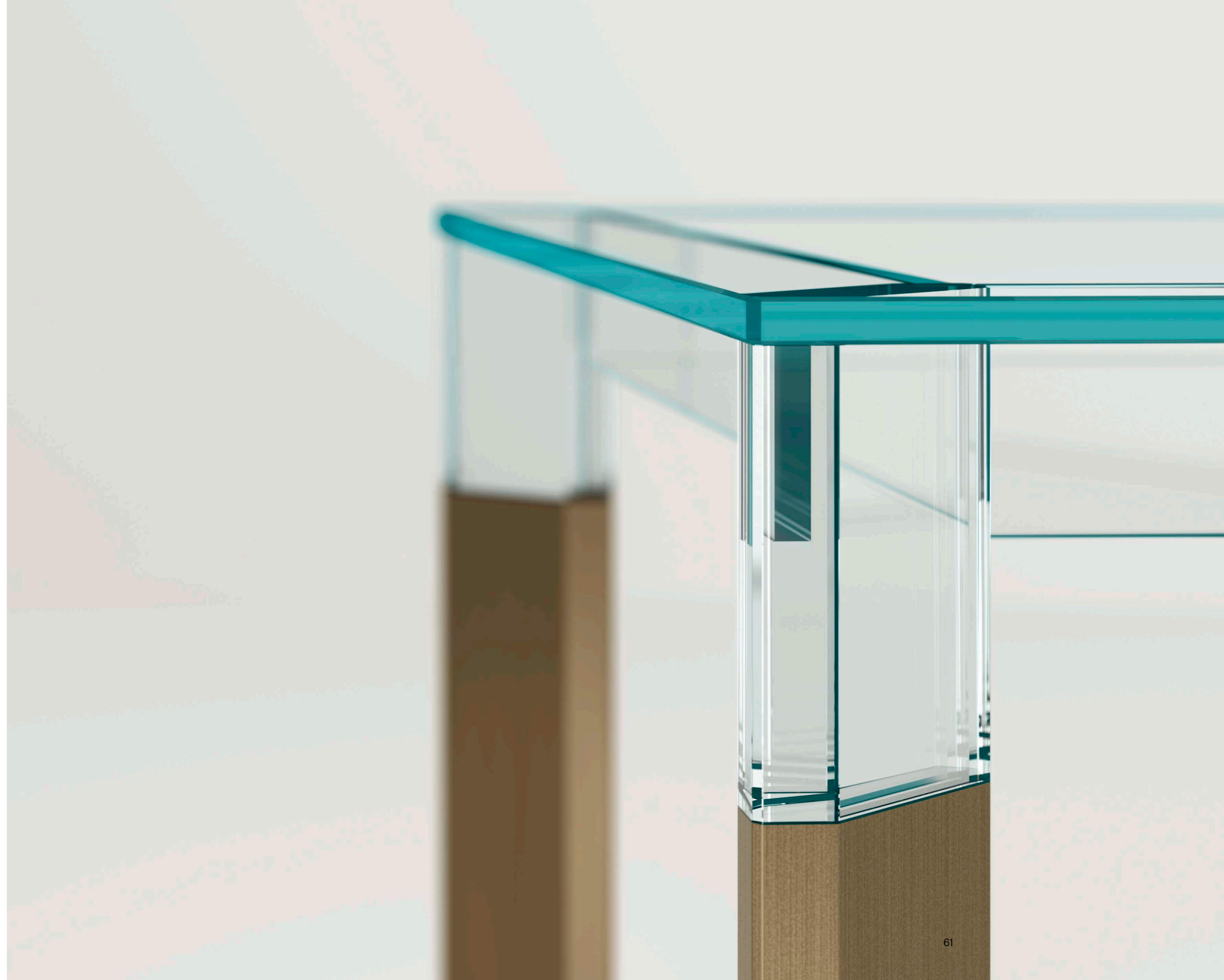



Perseo dining table

INFO TECNICHE / TECHNICAL INFO

Tavolo rettangolare o quadrato in vetro extra chiaro. Gambe smontabili nelle nuove finiture Antracite e Ottone spazzolato opaco.

Rectangular or square table in extra clear glass. Removable legs in the new finishes matt brushed Antracite or Ottone.

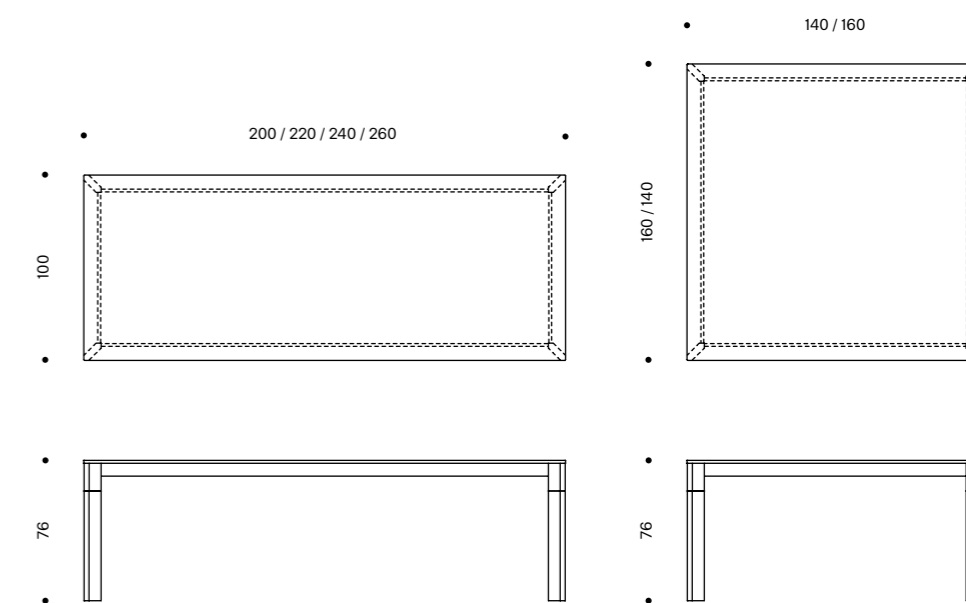

Hyperion
lamp

design
Massimo Castagna



Ad arricchire la collezione di lampade, nuove versioni da tavolo di Hyperion realizzate con le due dimensioni dei vetri di forma cubica arrotondata. Utilizzabili sia per uso singolo che insieme abbinando le diverse altezze e larghezze.

The lamp collection Hyperion is enriched by the new table lamp versions with two dimensions of the rounded cube shaped glass. It can be used individually or combining the different heights and widths.



Elementi di grande pulizia formale che trovano collocazione all'interno dei vari ambienti della casa, dalla zona living alla zona notte fino allo studio.

Elements of very clean shapes that can be placed in several areas of a home, from the living area to the sleeping area or the office.





Hyperion lamp

INFO TECNICHE / TECHNICAL INFO

Collezione di lampade da tavolo. Luce LED G9 3000K. Lampadina dimmerabile. Cubi in vetro pyrex soffiato trasparente. Parti metalliche disponibili nelle finiture cromo lucido, oro lucido e canna di fucile lucido.

Collection of table lamps. LED light G9 3000K. Dimmable bulb. Cubes in transparent blown Pyrex glass. Metal parts available in polished chrome, polished gold and polished gunmetal.

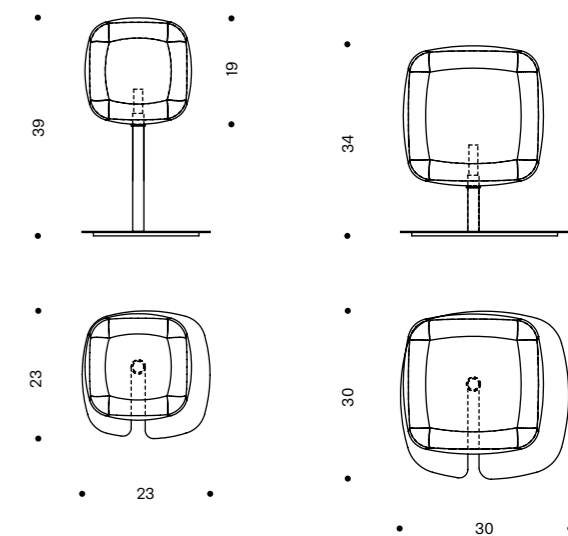

Maybe
mirror

design
Massimo Castagna

Specchio da parete pensato per creare diverse composizioni grazie al suo segno grafico. Una texture molto elegante e raffinata ottenuta dalla sovrapposizione di specchi diversi per forma e dimensione.

Wall mirror intended for the creation of different compositions thanks to its graphic design. A very elegant and refined texture obtained by the juxtaposition of mirrors of different shapes and dimensions.



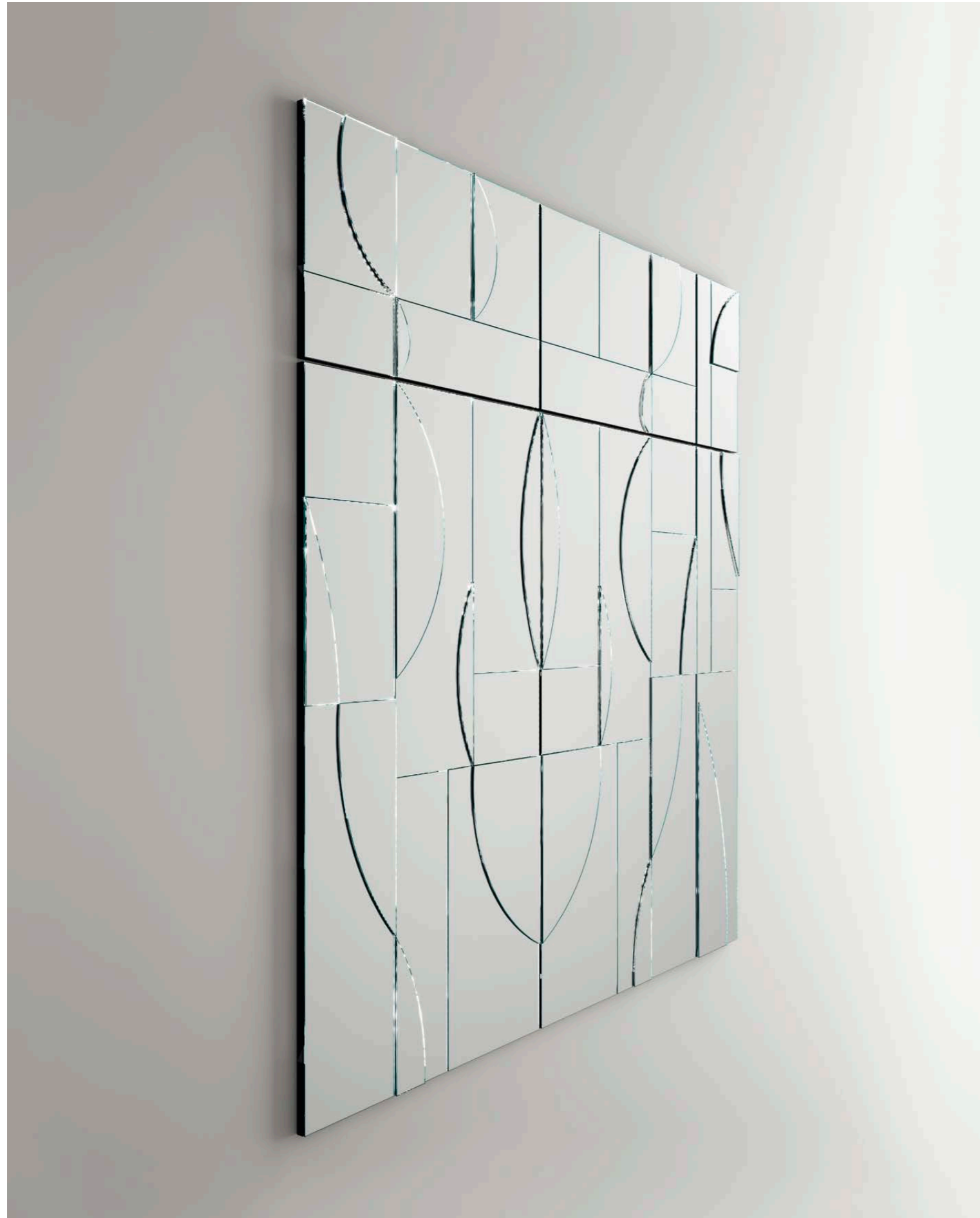

Maybe mirror

INFO TECNICHE / TECHNICAL INFO

Specchio modulare a parete realizzato con struttura in legno. E' disponibile in specchio, specchio oro, bronzo o fumé.

Modular wall mirror made with wooden structure. Available in mirror, gold, bronze or smoked mirror.

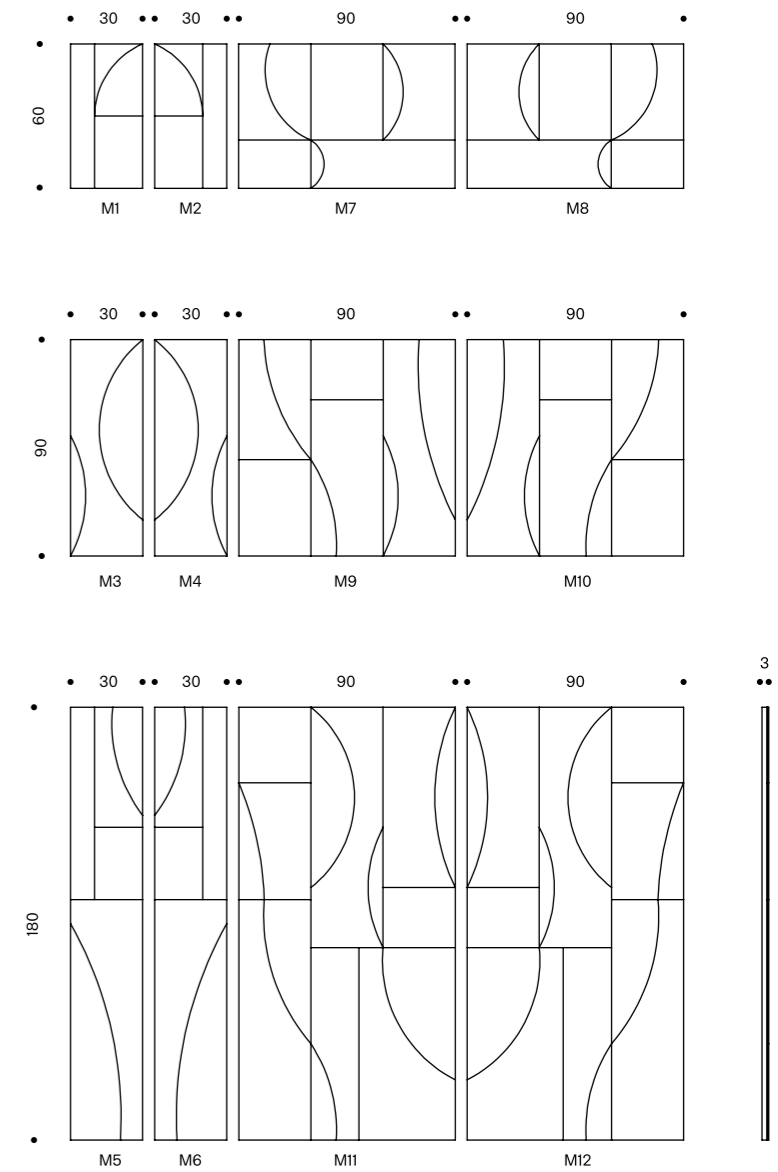

She
chair

design
Massimo Castagna

Dal design contemporaneo, la sedia She è frutto dell'incontro tra innovazione tecnologica e lavorazione artigianale.

A contemporary design, the She chair is the result of the encounter between technological innovation and artisan processing.



She è caratterizzata da una struttura in tondino metallico piegato e da una imbottitura finemente lavorata con cuciture esterne per una funzione sia tecnica che estetica. Ideale sia nel contesto domestico che in ambito contract grazie al suo design senza tempo e alla sua grande comodità.

She is characterized by a structure made of bent metal rod and upholstery finely processed with external stitching granting both technical and aesthetic functionality. Ideal for either domestic use or for contract thanks to its timeless design and great comfort.











She chair

INFO TECNICHE / TECHNICAL INFO

Sedia con struttura in tubolare di metallo da 20mm, disponibile nelle finiture cromo lucido e canna di fucile lucido o verniciata goffrata nero, grigio antracite e bianco. Seduta e schienale imbottiti in pelle o ecopelle.

Chair with rod shaped metal structure of 20mm, available in following finishes: polished chrome and polished gunmetal or embossed matt black, white or anthracite grey lacquered. Upholstered seat and backrest in leather or faux leather.

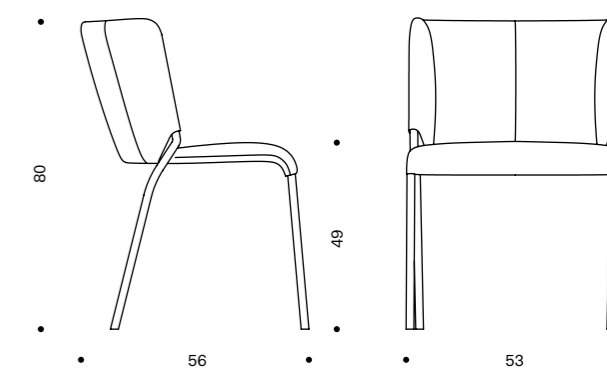

She chair
pelle / leather

Blu / Blue
164



Marrone / Brown
165



Bordeaux
166



Testa di moro
167



Nero / Black
168

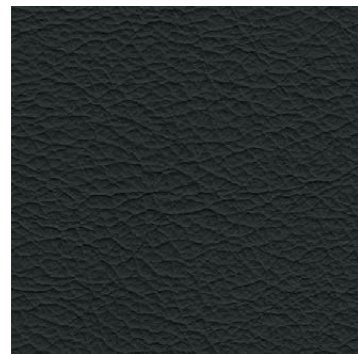

Bianco / White
171

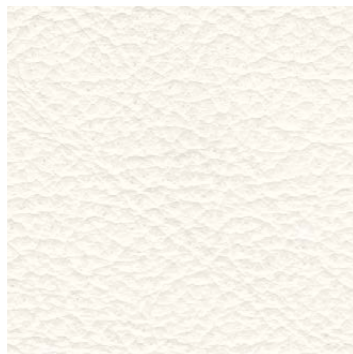

Marrone scuro / Dark brown
174



Beige
181



Grigio / Grey
185

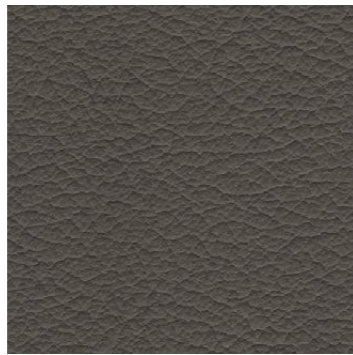

Marrone chiaro / Light brown
191

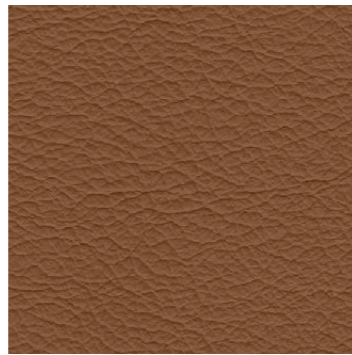

She chair
ecopelle / faux leather

1001

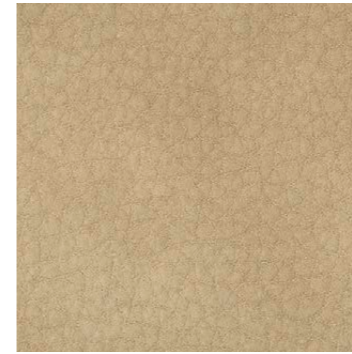

1002

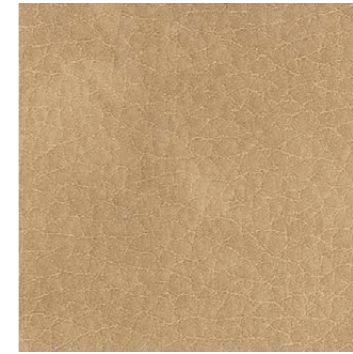

1003

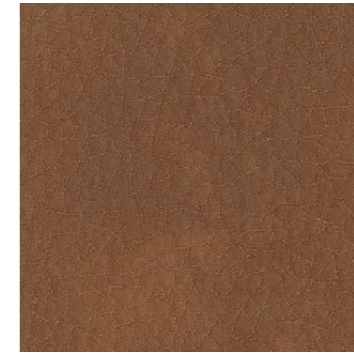

1004

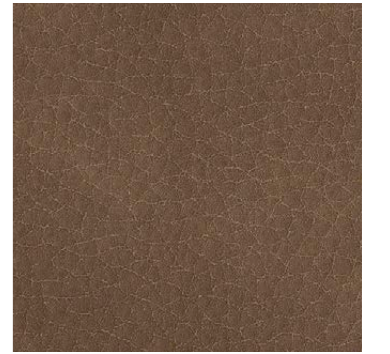

1005



1006

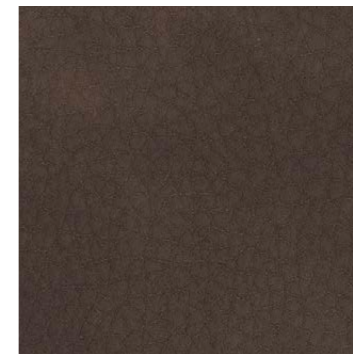

1007

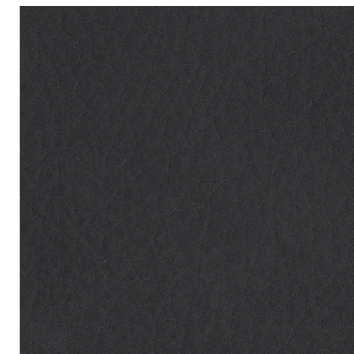

1008



1011

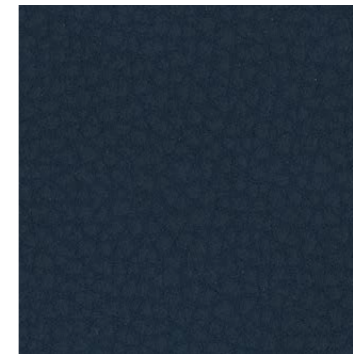

1014

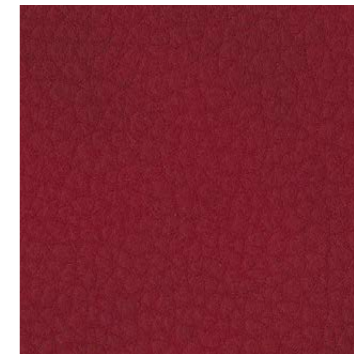



La riproduzione delle finiture su carta può riportare leggere differenze cromatiche rispetto agli originali.
Finishes reproductions on paper can differ slightly from the original ones.

Tonellidesign

Tonelli Design

T.D. Srl
via Casali 40/42
61122 - Pesaro (PU) Italy
tel. +39 0721 481172
fax + 39 0721 481291
www.tonellidesign.it
info@tonellidesign.it
export@tonellidesign.it

 Tonelli design
 Tonelli_Design

The New Modernism

art direction
Massimo Castagna
AD Architettura

digital images
Garage121

graphic design
Enrico Severi Design

post production
MIC Studio

Published 2021

Tonelli Design
All rights reserved

Tonellidesign

Tonelli Design

T.D. Srl

via Casali 40/42

61122 - Pesaro (PU) Italy

tel. +39 0721 481172

fax + 39 0721 481291

www.tonellidesign.it

info@tonellidesign.it

export@tonellidesign.it

 Tonelli design

 Tonelli_Design